

ੴ ਸ੍ਰੀ ਵਾਗਿਗੁਰੂ ਜੀ ਕੀ ਫੁੱਲਿ

ਪੰਜਾਬ ਐਂਡ ਸਿੰਧ ਬੈਂਕ
(ਭਾਰਤ ਸਰਕਾਰ ਕਾ ਉਪਕਰਮ)



Punjab & Sind Bank
(A Govt. of India Undertaking)

Where service is a way of life

ZONAL OFFICE BAREILLY



**OPEN TENDER FOR PROPOSED INTERIOR FURNISHING, ELECTRICAL, DATA
CABLING & AC WORKS FOR NEW BRANCH DHAURA TANDA, PUNJAB AND
SIND BANK**

TECHNICAL BID

&

FINANCIAL BID

ARCHITECT/ENGINEER:-

M/s Yogendra Architects
C/O Mr. Y. M. Sexena
Kamal Talkies Building, Bareilly-243001,
Uttar Pradesh Mob No. 9837031080
(E-mail : archyogendra@yahoo.co.in)

NOTICE INVITING TENDER

Dear Sir's,

Subject: Tender for Proposed Interior Furnishing, Electrical, AC and Data cabling works for new branch Dhaura Tanda, Punjab and Sind Bank

The Zonal Office, Punjab and Sind Bank, 148 Civil Lines, Bareilly, Uttar Pradesh- 243001 invites tenders for Interior Furnishing, Electrical, AC and Data cabling works for new branch Dhaura Tanda. Tender copies will be available for download from the website of Bank '<http://www.punjabandsindbank.co.in/module/tender-list>' from **03/05/2024 to 17/05/2024**.

Tenders should be submitted to the office not later than **16.30 Hrs. on 17/05/2024**.

The Earnest Money Deposit of Rs.33,000/- (Rupees Thirty Three only) by Fixed Deposit shall be submitted along with the tender in separate sealed envelope. Defect Liability and free maintenance period shall be twelve months from the date of virtual completion of the works. Validity of offer shall be 120 days from the date of opening of the tender.

Sealed tenders, in the prescribed tender form as

- 1. EMD & Technical bid along with the mandatory information**
- 2. Financial bid**

All the envelopes 1 & 2 should be addressed to The Zonal Manager, Punjab and Sind Bank, 148 Civil Lines, Bareilly, Uttar Pradesh- 243001 and super scribed "Tender For For Proposed Interior Furnishing Works, Electrical Works, AC & Data Cabling Works For New Branch Dhaura Tanda Punjab and Sind Bank "

Tenders should be submitted to the office not later than **16:30 HRS. on 17/05/2024**. The Technical Bids shall be opened at 17:00 HRS. on 17/05/2024 & Opening of Financial Bids will be informed to per-qualified bidders later on.

In case the date of opening of tenders is declared as a holiday, the tenders will be opened on the next working day at the same time.

The Bank does not bind itself to accept the lowest or any tender and reserves to itself the right to accept or reject any or all tenders, either in whole or in part, without assigning any reason for doing so.

Thank you,

Yours Faithfully,

-sd-

**TARA CHAND MEENA
ZONAL MANAGER**

Tender Documents for proposed Furnishing & allied works for BO Dhaura Tanda

TENDER INFORMATION & ELIGIBILITY CRITERIA

Separately Sealed Technical bid and financial bid i.e. Item Rates Tenders are invited on behalf of The Zonal Manager Office, Punjab and Sind Bank, 148 Civil Lines, Bareilly Uttar Pradesh -243001 from competent contractors. The contractors should be technically sound and financially capable.

The details are as under:

Name of Work	Tender for proposed interior furnishing works, electrical works, AC & data cabling works for new branch Dhaura Tanda, Punjab and Sind Bank.
Earnest Money Deposit	Rs.33,000.00 by Fixed Deposit in favour of 'Zonal Office, Punjab and Sind Bank, Bareilly' OR MSME certificate in lieu of EMD
GST Registration	To participate in bidding process, the bidder must have valid GST number
Electrical License	To participate in bidding process, the Contractor/Firm should have valid License from the concerned authority to carry out Electrical contract works.
Minimum work experience	To participate in bidding process, the contractor/Firm should have at least completed one similar works costing Rs8.80 lacs or two similar works costing Rs6.60 lacs each or three similar works costing Rs4.40 lacs for any Bank/Financial Institute in the last 5 years.
Financial strength	To participate in bidding process, the contractor/Firm should have Average Annual turnover for the last three years should be more than 4 Lakhs.
EMD & Technical Bid Documents	To be Sealed in Envelop no.1
Financial/Commercial Bid	To be Sealed in Envelop no.2
Time of Completion	20 days from the date of commencement
Issue of Tender	Tender Document will be available from Bank's Web Site www.punjabandsindbank.co.in/module/tender-list From 03/05/2024 to 17/05/2024 . Separately Sealed as mentioned above Tenders with the name of work subscribed on top of the cover to be submitted at The Zonal Office Punjab and Sind Bank, Bareilly on or before 17/05/2024 up to 16:30 hrs
Time & Date of Opening of	Technical Tender Bid Opening is scheduled at 17:00 hrs 17/05/2024 . The Opening of Commercial/Financial Bid will be informed to the qualified bidders later on.

Tender Documents for proposed Furnishing & allied works for BO Dhaura Tanda

Tender Rights	Conditional Tenders will not be accepted. The Punjab and Sind Bank reserves the right to accept or reject any or all the tenders without assigning any reason thereof or to accept any tender in part thereof.
Date of Commencement	On Issue of Work Order
Technical Quarries	A Vendor may contact Architect/Consultant's Office during 03/05/2024 to 17/05/2024 between 11:00AM to 17:00PM above mentioned address to clarify on the queries of the intending tenderers, received in writing prior to that date.
Initial Security Deposit (ISD)	3 % of the Contract value Less EMD (The Security Deposit shall be forfeited if the Contractor fails to observe any terms and conditions of the Contract.)
Defects Liability Period	12 months from the date of issue of Virtual completion and over the site to Bank.
Retention Money	10% retention money from Final Bill.
Terms of Rate	The rates shall be at site of work shall be inclusive of all taxes. However GST will be paid Extra
Period of validity of Tender	120 Days from the date of opening tender.
Period of honoring final bill	30 working days from the receipt of Certificate from Architect of final bill.
Validity of rates after award of Tender	No escalation in price will be allowed
Release of Retention Money	Retention Money shall be released after Satisfactorily completion of Defects Liability period of 12 months.

FORM OF TENDER

To,
THE ZONAL MANAGER,
PUNJAB & SIND BANK,
148 CIVIL LINES,
BAREILLY – 243001 (UP)

Dear Sir,

Ref: Tender for Proposed interior furnishing, electrical, AC and Data cabling works at new branch Dhaura Tanda, Punjab and Sind Bank.

Having examined the plans, specifications and schedule of quantities prepared by your Architect, M/s Yogendra Architects, C/O Mr. Y. M. Sexena, Kamal Talkies Building, Bareilly-243001, and satisfying ourselves as to the location of the site and working conditions, I/we hereby offer to execute the above works at the respective rates which I/ we have quoted for the items in the Schedule of Quantities.

I/We herewith deposit Rs.33,000/- of Fixed Deposit in favor of The Zonal Managar Office, Punjab and Sind Bank, Civil Lines, Bareilly, Uttar Pradesh- 243001 as the Earnest Money Deposit for the execution of the works at my/our tendered rates together with any variations. Or I/We submit herewith MSME certificate in lieu of Tender Fees and Earnest Money Deposit in terms of GoI guidelines.

In the event of this tender being accepted, I/we agree to enter into and execute the necessary contract required by you. I/We do hereby bind myself/ourselves to forfeit the aforesaid deposit of Rs.33,000/- in the event of our refusal or delay in signing the Contract Agreement. I/we further agree to execute and complete the work within the time frame stipulated in the tender documents. I/we agree not to employ Sub- Contractors without the prior approval of the Bank.

I/we agree to pay GST , Sales Tax, Works Contract Tax, Excise Tax, Octroi, VAT, Duties, all Royalties and all other applicable taxes prevailing and be levied from time to time on such items for which the same are livable and the rates quoted by me/us are inclusive of the same.

I/we understand that you are not bound to accept the lowest tender or bound to assign any reasons whatsoever for rejecting our tender.

I/we further understand that Punjab and Sind Bank may award Contracts for “Tender for proposed interior furnishing works, electrical works, AC & data cabling works for new branch Dhaura Tanda, Punjab and Sind Bank" to more than one Contractors and that I/ we shall make no claims what so ever if Punjab and Sind Bank accept only a part of my/our tender. We unconditionally agree to Punjab and Sind Bank preconditions or stipulated in the tender documents.

I/We agree that in case of my/our failure to execute work in accordance with the specifications and instructions received from the Bank or the Architect/Consultants appointed by the institute, during the course of the work, Bank reserves the right to terminate my contract and forfeit the Earnest money deposit paid by me in additions to recovery of all the dues to the institute from the payment receivable by me. Further I may also be barred from tendering in future for the institute and its subsidiaries.

Tender Documents for proposed Furnishing & allied works for BO Dhaura Tanda

I/we enclose Fixed Deposit for Rs.33,000/- towards Earnest Money deposit OR MSME certificate in lieu of Tender Fees & EMD in envelope No. 1

I/we agree to keep our tender open for 120 days from the date of opening of envelope No.1 i.e. (Technical bid & EMD).

I/we enclose herewith the completed tender documents duly signed in envelope No. 2 (Commercial/Financial Bid)

Yours Faithfully,

[To be signed by the Authorized Representative of Tenderer holding Power of Attorney]

Place:

Date:



Tender Documents for proposed Furnishing & allied works for BO Dhaura Tanda

MANDATORY INFORMATION

Mandatory information required for Pre-qualification of the bidder for Tender for Proposed interior furnishing works, electrical works, AC & data cabling works for new branch Dhaura Tanda, Punjab and Sind Bank.

1.	Name of Organization	
2.	Status of Firm (Company/ Partnership/ Proprietorship/ Individual)	(submit proof)
3.	Registered Address	Postal Address Mobile No: Email: (Submit proof)
4.	Communication Address	Postal Address Mobile No: Email: (Enclosed copy of Proof of Office address)
5.	Year of Establishment	
6.	Name of Director/Partner/Proprietor	
7.	Registration Details Companies/Firm	Registration No and Date- (Submit proof)
8.	Income Tax Number (Copy of GST certificate/PAN)	PAN- GST-
9.	Average Annual turnover for the last three years should be more than 4 Lakhs.	Furnish copies of Balance Sheet and Profit & loss account (audited/self attested) for the last three years. (FY 2020-21, 2021-22, 2022-23)
10.	Latest solvency certificate from your Banker for not less than Rs 4 Lacs	Name of Bank- (enclosed copy)
11.	The contractor/Firm should have at least completed one similar works costing Rs8.80Lakh or two similar works costing Rs6.60Lakh each or three similar works costing Rs4.40Lakh for any Bank/Financial Institute in the last 5 years. Note: Similar works means, the vendor should have completed comprehensive work consisting of Furnishing work being the selection criteria.	Name of Client Value of Work Year i) ii) iii) (enclosed copy of completion certificate & work order from clients preferred)
12.	The Contractor/Firm should have valid License from the concerned authority to carry out Electrical contract works	License No- Valid upto- (enclosed copy of valid electrical license)
13.	If you are registered in panel of other organization / Statutory bodies such CPWD, PWD, MES,PSU Banks, etc, furnish their name, Category and date of registration.(furnish proof)	i) ii) iii) iv)
14.	Details of EMD	DD No :

Tender Documents for proposed Furnishing & allied works for BO Dhaura Tanda

		Date : Issuing Bank/Branch:
15.	Details of MSME (if not submitting EMD, Tender Cost)	Registration No: (Furnish UDYAM registration certificate)

DECLARATION

1. All the information furnished by me / us here above is correct to the best of my knowledge and belief.
2. I / we have no objection if enquiries are made about the work listed by me / us in the accompanying sheets / Annexure.
3. I / We agree that the decision of Bank in selection of contractors will be final and binding to me / us.
4. I / We have read the instructions and I / we understand that if any false information is detected at a later date the contract/work order shall be cancelled at the discretion of the Bank.
5. I / We undertake that the bidder/contractor/firm has not been declared Blacklisted and/or ineligible to participate for corrupt, fraudulent or any other unethical business practice by any other organization / Statutory bodies such CPWD, PWD, MES, PSU, Banks, etc

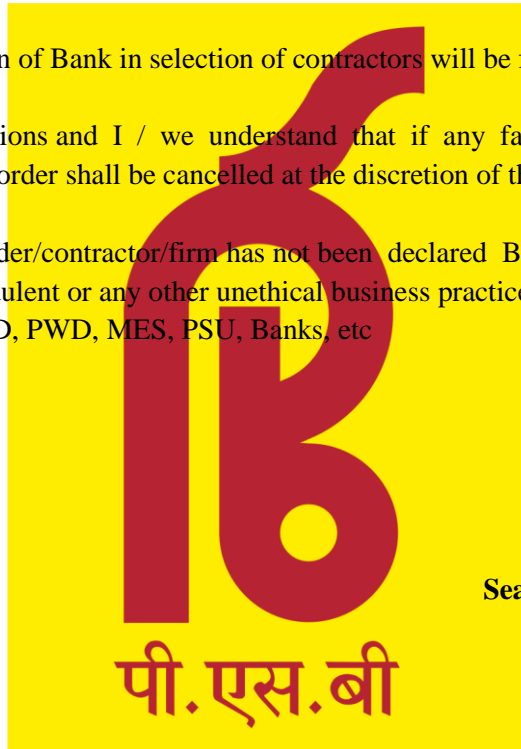

Seal and Signature of the Bidder/s.

Date:

Place:

Instructions to Tenderer

1. Location: The site is located at Dhaura Tanda, Bareilly-243202, Landowner- Mohd Zahid.

Tenderers must get acquainted with the proposed work and study drawings, designs, specifications, conditions of contract and other conditions carefully before tendering. The Tenderer shall seek clarifications on any item, if required, prior to submitting his tender. No request of any change in rates or conditions for want of information on any particular point shall be entertained after receipt of the tenders. The Tenderer is advised to inspect the site to ascertain the nature of site, access thereto, location, facilities for procurement of materials, labour rates and execution of the work. The Tenderer shall be deemed to have full knowledge of the site and drawings whether or not he actually inspects them.

2. Submission of Tender: - Tender must be submitted in original to The Zonal Manager, Punjab and Sind Bank, 148 Civil Lines, Bareilly, Uttar Pradesh- 243001 and as per details given hereunder. The rates shall be filled in the Schedule given in, of the tender document. In case of any queries, the Tenderer may contact Architect.

- The Tenderer is requested to quote strictly as per the terms and conditions and specifications given in the tender document and not to stipulate any deviations. However, deviations, if unavoidable, should be indicated separately indicating the specific page number and clause number against which the deviations are made. Wherever specifications of certain works are not available they shall be deemed to be done as per relevant Scope.

- Addenda to this tender document, if issued, must be signed and submitted along with the tender document.

- All pages to be initialed:

- All signatures in tender documents shall be dated and stamped. All pages of tender documents shall be initialed at the lower right hand corner or signed wherever required in the tender papers by the Tenderer or by a person holding power of attorney authorizing him to sign on behalf of the Tenderer before submission of tender.

3. Rates to be in figures and words: The Tenderer should quote in English both in figures as well as in words the rates and amounts tendered by him in the Schedule of Rates for each item and in such a way that interpolation is not possible. The amount for each item should be worked out and entered and requisite totals given of all items both in figures and in words. The tendered amount for the work shall be entered in words and figures in the tender and duly signed by the Tenderer.

4. Corrections and Erasures: No corrections and alterations in the entries of tender papers shall be permitted. If any they shall be signed and dated in full by the Tenderer. Corrections with white fluid and overwriting are not permitted.

- The tender shall contain the names, postal address of the residence and place of business of authorized person signing the tender and shall be signed in /his usual signature. Partnership firms shall furnish the full names of all Partners in the tender. It should be signed in the partnership name by all the partners or by duly authorized representative followed by the name and designation of the person signing. An authorized representative shall sign tender by a Corporation, and a power of Attorney on their behalf shall accompany the tender. A copy of the partnership deed of the firm with names of all partners shall be furnished.

- When a Tenderer signs a tender in a language other than English, the total amount tendered should, in addition, be written in the same language. The signatures should be attested by at least one witness.

Tender Documents for proposed Furnishing & allied works for BO Dhaura Tanda

5. Witness: Witnesses and sureties shall be persons of status and propriety and their names, occupation and address shall be stated below their signatures.

6. Transfer of Tender Documents: Transfer of tender documents purchased by one intending Tenderer to another is not permitted.

7. Earnest money: The Tenderer shall pay the amount of Earnest Money as mentioned in the Notice Inviting Tender, by Bank Demand Draft/Banker's Cheque payable to The Zonal Office, Punjab and Sind Bank, 148 Civil Lines, Bareilly, Uttar Pradesh- 243001. No interest on Earnest Money deposited by the Tenderer shall be allowed.

The Earnest Money of an unsuccessful Tenderer will be refunded, without any interest, soon after the decision to award the work is taken. The Earnest Money deposited by the successful Tenderer shall be retained as part of Security Deposit. The Security Deposit shall be forfeited if the Contractor fails to observe any terms and conditions of the Contract.

8. Validity: Tenders submitted by Tenderer shall remain valid for acceptance for a period up to 120 days from the date of opening of tender. The Tenderer shall not be entitled during the period of validity, without the consent in writing of Bank to revoke or cancel his tender or to vary the tender given or any terms thereof.

9. Addenda: Addenda to the tender document may be issued if required to clarify documents or to reflect modifications to the design or contract terms. Each addendum issued by the Architect/Interior Designer will be distributed to each person or organization to which a set of tender documents has been issued. Each recipient will submit the same along with his tender. All addenda issued by the Architect/Interior Designer shall become part of Tender Documents.

10. Right to accept or reject tender: The acceptance of a tender will rest with the Bank who do not bind themselves to accept lowest tender and reserve to themselves the authority to reject any or all the tenders received without assigning any reasons. They also reserve the right of accepting the whole or any part of the tender and the Tenderer shall be bound to perform the same at the rates quoted. All tenders in which any of the prescribed conditions are not fulfilled or are incomplete in any respect or there is any correction not duly signed and dated by the Tenderer are liable to be rejected. For this purpose Tenderer shall quote rates for various items which will be self sufficient to meet their whole costs for executing any / every item. No demand for variations in rates for items executed shall be entertained on the plea of the Bank deciding to delete, alter or reduce the quantities specified in respect of the item.

11. Rates: The Bank is not concerned with any rise or fall in the prices of materials and labour. The rates quoted shall include all costs, allowances, taxes including sales tax on works contract or any other charges including any enhanced labour rates etc. which may become effective for any reason including those due to acts of Government/ Statutory Bodies enacted from time to time by the State and or the Central Government. Under no circumstances, shall the Bank be held responsible for compensation or loss to the contractor due to any increase in the cost of labour or materials etc. HOWEVER GST WILL BE PAID EXTRA The rate quoted in the tender by the contractor should include cost of 3 sets of 10" x 12" photographs done by a reputed professional photographer, of the completed work. Contractor to include cost of pest control treatment of the entire site, including white ants, roaches, rodents for one year from date of virtual completion of the contract. Contractor to coordinate and assist the Architect/Interior Designer in obtaining all statutory approvals including MMC, CFO and any other State and Central rules in force. Any expenses incurred in obtaining such approvals are deemed included in the rates quoted by the Contractors.

Tender Documents for proposed Furnishing & allied works for BO Dhaura Tanda

12. The entire civil & furnishing work shall be guaranteed to be free from manufacturing defects, defective workmanship or materials and any defects that may appear within 12 months from the date of issue of completion certificate which in the opinion of the Bank/Consultants have arisen from bad manufacturing, workmanship or materials, shall upon intimation be made good by the Contractor at his own cost within the time specified. During the said period of 12 months the Contractor shall without any extra cost, carry out all routine and special maintenance of the Works and attend to difficulties and defects that may arise. The Tenderer / Contractors shall associate with him during the execution and free service period, the operation and maintenance staff of the Bank.

13. Payments for the work to be executed under this contract shall be made as per the tender document, and no variation in the mode of payment will be acceptable.

14. The Tenderer shall guarantee that the work shall conform to the detailed specifications.

15. Before handing over the civil & furnishing Works, 6 copies shall be furnished to the Bank along with 6 sets of "as built" drawings of all the works done as executed by the contractor. In addition to hard copy of as built drawings, the contractor shall also supply a computer CD containing these drawings in a digital form (done with Auto CAD-2010 or above version) similarly the operation and maintenance manual etc. shall also be supplied in a CD with suitable indexing format for easy retrieval and reference.

16. Signing of the contract: - The successful Tenderer shall be required to execute an agreement in the proforma attached with this tender document within 3 days from the date of receipt of the notice of acceptance of tender. In the event of failure on the part of the successful Tenderer to sign the agreement within the above stipulated period. The Bank reserves the right to forfeit the earnest money/ security deposit and cancel the contract. Until the Agreement is formally signed, the Work Order / Letter of Acceptance of Tender issued to the Successful Tenderer and accepted by him shall be operative and binding on the Bank and the Contractor.

17. On acceptance of the tender, the name of the accredited representatives of the Tenderer who would be responsible for taking instructions from the Bank shall be mentioned by the Tenderer.

18. If so decided, the Bank reserves the right to appoint/change architect or any other agency to get the quality of works checked, measurements recorded, including certification of bills etc.

19. I / We hereby declare that I / We have read and understood the above instructions for the guidance of tenderers.

20. The Bank reserves the right to reproduce partly or fully the items executed on site anywhere in the country premises and any contractor of any description shall make no copyright claims from the Bank.

21. The Bank has the right to delete items, reduce or increase the scope of work without the contractor claiming any compensation for the reduction in the scope of work.

Signature of Tenderer:

Address:

Date:

ARTICLE OF AGREEMENT

Article of Agreement made this at Bareilly in this day of 2024, between the The Zonal Office, Punjab and Sind Bank, 148 Civil Lines, Bareilly, Uttar Pradesh- 243001 (hereinafter called “the Employer” of the one part), and Name : M/s (Hereinafter called the contractor of the other part) where as the Employer is desires of having “Tender for Proposed interior furnishing, electrical, AC and data cabling works for new branch Dhaura Tanda, Punjab and Sind Bank” and has caused drawings and specifications describing the work and bills of quantities prepared through its appointed Architect/Engineer M/s Yogendra Architects, C/O Mr. Y. M. Sexena, Kamal Talkies Building, Bareilly-243001 and whereas the said drawings have been seen, the specifications and/or the schedule of quantities have been signed by or on behalf of the partners have hereto the contractor and whereas the contractor has agree to execute upon and subject to all conditions of contract (all of which are collectively hereinafter referred to as “the said conditions”) the work shown upon the said drawing and/or described in the said specifications and included in the said schedule of quantities at the respective rates therein set forth amounting to the sum as therein arrived at of such other sum as shall become payable there under (hereinafter referred to as “the said contract amount”).

NOW IT IS HEREBY AGREED AS FOLLOWS

In consideration of the said contract amount to be paid at the time and in the manner set forth in the said conditions execute and complete the work shown upon the said drawings and described in the said specifications and the schedule of quantities, either in whole or in part.

The employer shall pay the contractor they said contract amount or such other sum as shall become payable at the time and in the manner hereinafter specified in the said conditions.

The term “the Architects” in the said conditions shall mean the said M/s Yogendra Architects, C/O Mr. Y. M. Sexena, Kamal Talkies Building, Bareilly-243001, or in the event of their death or ceasing to be the architects for the purpose of this contract, such other person or persons as shall being a nominated for the purpose by the employer not being a person to whom the contractor shall object for reasons (maintained in said conditions) considered to be sufficient by the employer. Provided always that no person or persons subsequently appointed to be architects under this contract shall be entitled disregard or over rule any previous decision or approval or direction given or expressed in writing by the architects for the time being.

The said conditions an appendix shall be read and construed as forming part of this agreement and the parties hereto shall respectively abide by to submit themselves to the conditions and perform the respective agreements on their part as contained in the said conditions contained.

The “Architect” refers to M/s Yogendra Architects, C/O Mr. Y. M. Sexena, Kamal Talkies Building, Bareilly-243001.

The plans, agreement and documents mentioned herein shall from the basis of this contract. The contract is neither a fixed lump sum contract nor a piece work contract, but is a item rate contract to carry out work in respect of Tender for Proposed interior furnishing, electrical, AC and data cabling works for new branch Dhaura Tanda, Punjab and Sind Bank and also some addition and alteration works to be paid for according to actual measured quantities at the rates contained in the schedule of rates and probable quantities as provided in the said conditions.

Tender Documents for proposed Furnishing & allied works for BO Dhaura Tanda

The contractor shall afford every reasonable facility for the carrying out of the all works relating to “Tender for Proposed interior furnishing, electrical, AC and data cabling works for new branch Dhaura Tanda, Punjab and Sind Bank”. Preparing the furniture work and other ancillary works in the manner laid down in the said conditions, and shall make good and damage done to walls, floors etc. after the completion of his work.

The Employer through the architect and technical officer reserves to himself the right of altering the drawing and nature of the work of having portions of the same carried out without prejudices to this contract.

The said conditions shall be read and construed as forming part of this agreement and the parties hereto will respectively abide by to submit themselves to the conditions and stipulations and perform the agreements of their parts, respectively in such conditions contained.

Time shall be considered as the essence of this agreement and the contractor hereby agrees to commence the work soon after the formal work order issued to him and complete the entire work within time as mentioned below from Work order Issued.

All payments by the Employer under this contract will be made only at Bareilly.

All disputes arising out or in any way connected with this agreement shall be deemed to have arise in Bareilly and only the Courts in Bareilly shall have jurisdiction to determine the same.

The several parts of this contract have been read and fully understood by the contractor. In witness whereof the employer if the contractor have set partnership or their respective hands to these individual. Presents and two duplicates here of the day and year first here in above written.

In witness where of the parties hereof the Employer if the contractor has set its hand to these company.

Presents its duly authorized official and the contractor has caused its common seal to be affixed hereunto and the said two duplicates has caused these presents and the said two duplicates hereof to be excavated on its behalf, the day and year first herein above written.

SIGNATURE CLAUSE

SIGNED AND DELIVERED BY	Signature:
By the hand of Shri	Name:
In the presence of	Witness:
If the party is a partnership firm or an individual should be signed by all or on behalf of all the partners.	
SIGNED AND DELIVERED BY	Signature:
By the hand of Shri	Name:
In the presence of	Witness:
The Common Seal of (Firm)	

Code of Integrity

1. No official of a procuring entity or a bidder shall act in contravention of the codes which includes prohibition of

- a) Making offer, solicitation or acceptance of bribe, reward or gift or any material benefit, either directly or indirectly, in exchange for an unfair advantage in the procurement process or to otherwise influence the procurement process.
- b) Any omission or misrepresentation that may mislead or attempt to mislead so that financial or other benefit may be obtained or an obligation avoided.
- c) Any collusion, bid rigging or anti- competitive behavior that may impair the transparency, fairness and the progress of the procurement process.
- d) Improper use of information provided by the procuring entity to the bidder with an intent to gain unfair advantage in the procurement process or for personal gain.
- e) any financial or transactions between the bidder and any official of the procuring entity related to tender or execution process of contract; which can affect the decision of the procuring entity directly or indirectly.
- f) Any coercion or any threat to impair or harm, directly or indirectly, any party or its property to influence the procurement process.
- g) Obstruction of any investigation or auditing of a procurement process.
- h) Making false declaration or providing false information for participation in a tender process or to secure a contract.

2. Disclosure of conflict of interest.

3. Disclosure by the bidder of any previous transgressions made in respect of the provisions of sub-clause (1) with any entity in any country during the last three years or of being debarred by any other procuring authority.

- (i) The procuring entity, after giving a reasonable opportunity of being heard, comes to the conclusion that a bidder or prospective bidder, as the case may be, has contravened the code of integrity, may take appropriate measures.
- (ii) The procuring authority should be satisfied that the selected offer adequately meets the requirements and the price of the selected offer is reasonable and consistent.
- (iii) Procuring authority must place on record precisely the considerations which weighed while taking the procurement decision

THE CONDITIONS OF CONTRACT

GENERAL CONDITIONS OF CONTRACT

In construing these conditions and the specifications, Schedule of Quantities and Contract Agreement, the following words shall have the meanings herein assigned to them except where the subject or context otherwise requires:

"Bank" shall mean 'The Zonal Manager, Punjab and Sind Bank, 148 Civil Lines, Bareilly, Uttar Pradesh-243001' and the "Architect/Consultant" shall mean 'M/s Yogendra Architects, C/O Mr. Y. M. Sexena, Kamal Talkies Building, Bareilly-243001' appointed by The Zonal Manager, Punjab and Sind Bank, 148 Civil Lines, Bareilly-243001 for the said works.

"Contractor" / "Contractors" shall mean the person or the persons, firm or company whose tender has been accepted by the Bank and shall include his/their heirs, and legal representatives, the permitted assigns and successors.

"This Contract" - Shall mean the Articles of Agreement, the conditions, the Appendix, the Schedule of Quantities and specifications attached hereto and duly signed.

Tender Documents for proposed Furnishing & allied works for BO Dhaura Tanda

"Site" - Shall mean the site of the contracted works including any building and erection thereon and any other land (inclusively) as aforesaid allotted by the Bank for the contractor's use.

"Works" shall mean the works to be executed and recorded in accordance with the Contract and shall include all extra or additional altered or substituted works as required and recorded for the performance of the Contract

"Contract Documents" shall include the notice inviting Tenders, the Articles of Agreements, the General Conditions of Contract, the special conditions of contract, the Appendices, the Schedule of Quantities, Specifications for Materials, Work-Sheet and mode of measurements, and drawings pertaining to the work. All sections of this Contract Document are to be read together. Further such correspondence between the Bank/Architect/ Consultant and Contractors as admitted by the Bank before award of work and thereafter shall also form part of contract documents.

"Drawings" shall mean the drawings referred to in the specifications, description of items etc. and any modifications of such drawings approved in writing by the Architect/Consultant and such other drawings as may from time to time be furnished or approved in writing by the Architect/Consultant.

"Notice in Writing" or written notice shall mean a notice in writing, typed or printed characters, sent by the Bank or Architect/Consultant (unless delivered personally or otherwise) proved to have been received by registered post to the last known private or business address or registered office of the contractors and shall be deemed to have been received by them when in the ordinary course of post it would have been delivered. "Act of Insolvency" shall mean any Act of Insolvency as defined by the Presidency Towns Insolvency Act, or the Provincial Insolvency Act or any Act amending such original act/s..

"Virtual Completion" shall mean that the works are in the opinion of the Architect/Consultant complete or fit for occupation.

Words importing persons include firms and Corporations, words importing the singular only also include the plural and vice versa where the context requires.

Headings and marginal notes to these conditions shall not be deemed to form a part thereof or be taken into consideration in the interpretation or construction thereof or of the contract. "Net Prices" - If in arriving at the contract amount the contractor shall have added to or deducted from the total of the items in the Tender any sum, either as a percentage or otherwise, then the net price of any item in the Tender shall be the sum arrived at by adding to or deducting from the actual figure appearing in the Tender as the price of that item a similar percentage of proportionate sum, provided always that in determining the percentage or proportion of the sum so added or deducted by the contractor the total amount of any Prime Cost Items and Provisional sum of money shall be deducted from the total amount of the Tender. The expression "net rates" or "net prices" when used with reference to the contract or accounts shall be held to mean rates or prices so arrived at. Words "importing persons" including firms and corporations. Words importing the singular only also include the plural and vice versa where the context requires.

SCOPE OF CONTRACT: The contract comprises of the construction, completion and maintenance of the works, provision of all labour, materials, constructional plant, temporary works and everything whether of a temporary or permanent nature required in and for such construction, completion and maintenance.

The Contractor shall carry out and complete the works in every respect in accordance with this Contract and with the directions of and to the satisfaction of the Architect/Consultant/Bank. The Architect/Consultant may in his absolute discretion and from time to time issue further drawings and/or written instructions, details, directions and explanations, which are hereafter collectively referred to as "instructions". These instructions shall be reflected either in the minutes or in any other form when Bank's approval/ consent is obtained in regard to:-

- The variation or modification of the design, quality or quantity of works or the addition or omission or substitution of any work.

Tender Documents for proposed Furnishing & allied works for BO Dhaura Tanda

- Any discrepancy in or divergence between the Drawings or between the Schedule of quantities and/or Drawings and/or specifications.
- The removal from the site of any materials brought thereon by the Contractor and the substitutions of any other materials thereof.
- The removal and/or re-execution of any works executed by the Contractor.
- The postponement of any work to be executed under the provisions of this Contract.
- The dismissal from the works of any person employed thereupon.
- The opening up for inspection of any work covered up.
- The amending and making good of any defects.
- Co-ordination of work with other agencies appointed by the Bank for due fulfillment of the total work.

The Bank shall have a right to delete any item of work from the scope of contract and contractor shall not make any extra claim on this account.

The Contractor shall forthwith comply with and duly execute any work contained in Architect/Consultants instructions whether oral or written, It is provided that verbal instructions, direction sand explanations given to the Contractor or his representative upon the works by the Architect/Consultant shall, if involving a variation, be confirmed in writing by the Contractor within 5 days and if not dissented from in writing within a further 10 days by the Architect/Consultant, such shall be deemed to be the Architect/Consultant's instructions within the scope of the contract.

If Compliance with the Architect/Consultant's instructions involves any variation, the Bank shall pay the Contractor on the Architect's certificate the price of the said work (As an extra to be valued by the Architect as hereinafter provided).

If the Contractor fails to comply with the Architect/Consultant's instructions within a fortnight after the receipt of written notice from the Architect/Consultant requiring compliance with such instructions, the Bank through the Architect/Consultant may employ some other agency to execute any work whatsoever which may be necessary to give effect to such instructions

For the purpose of entering day-to-day instructions by the Architect/Consultant, the Contractor shall maintain at his own cost, a "Site Instruction Book" in quadruplicate in which the instructions shall be entered by Architect/Consultant.

'Instruction' to the Contractor shall be generally issued through Architect/Consultant. However Architect/Consultant or Bank for the sake of urgency as a result of inspection may issue instructions directly.

GENERAL OBLIGATIONS

CONTRACT: The contractor shall enter into and execute a contract in the form annexed hereto within the line specified in the letter of intent and in default thereof the earnest money paid by the contractor shall be forfeited and acceptance of this tender shall be considered as withdrawn. The cost of the stamp of the agreement is to be borne and paid by the contractor.

- Until the Agreement is formally signed, the Work Order / Letter of Acceptance of Tender issued to the Successful Tenderer and accepted by him shall be operative and binding on the Bank and the Contractor.

EARNEST MONEY DEPOSIT: The Tenderer shall deposit an amount of as mentioned above in the form of Fixed Deposit drawn in favor of as mentioned above at the time of submission of tender as Earnest Money. No Interest shall be paid on this Earnest Money Deposit. The Earnest Money of an unsuccessful Tenderer will be refunded, without any interest, soon after the decision to award the work is taken. The Earnest Money deposited by the successful Tenderer shall be retained as part of Security Deposit.

The Earnest Money Deposit shall stand absolutely forfeited if the Tenderer revokes his tender at any time during the period when he is required to keep his tender open for acceptance by the Bank, or if, after the tender is accepted, the

Tender Documents for proposed Furnishing & allied works for BO Dhaura Tanda

Contractor fails to enter into a formal agreement/or if he fails to pay the security deposit as stipulated/or if he fails to commence the work within stipulated time limit.

The Tenderer may submit MSME certificate in lieu of EMD amount in terms of GoI guidelines.

SECURITY DEPOSIT: The successful Tenderer shall deposit an amount of 3 % of the Contract value Less EMD. The Security Deposit shall be forfeited if the Contractor fails to observe any terms and conditions of the Contract. The Security Deposit shall be refunded to the contractor without any interest after completion of all obligation under the contract.

RETENTION MONEY: Retention money shall be deducted from running account bills at 10% of gross value of certified work. The retention money i.e. 10% of certified work will be kept for complete defect liability period i.e. 12 months from completion of the work.

If the Contractors do not carry out the rectification work during the Defects Liability Period, the Banks shall have the right to get such defective work rectified after giving due notice in writing to the Contractors and recover the cost of repairs from the monies so retained.

ACCESS TO WORKS: The Architect/Consultant/Bank and any person authorized by them shall at all reasonable times have free access to the works, and to the workshops, Factories or other places where materials are being prepared or constructed for the Contract and also to any place where the materials are lying or from which they are being obtained. The Contractor shall give every facility to the Architect/Consultant/Bank and their representatives for inspection and examination and test of the materials and workmanship. No person unless authorized by the Architect/Consultant or the Bank, except the Representatives of Statutory Public Authorities authorized by the Bank, shall be allowed on the works at any time. If any work is to be done at a place other than the site of the works, the Contractor shall obtain the written permission of the Architect/Consultant/ Bank for doing so.

TENDERER TO VISIT SITE: Each Tenderer must before submitting his tender visit the site of works so as to ascertain the physical site conditions and prices, availability and quality of materials according to Specifications before submitting the quotations.

INSPECTION OF SITE AND SUFFICIENCY OF TENDER: The Contractor shall inspect and examine the site and its surrounding and shall satisfy himself before submitting his tender as to the form and nature of the site, the quantities and nature of access to the site, the accommodation he may require and in general, shall himself obtain all necessary information as to risk, contingencies and other circumstances which may influence or affect his tender.

The Contractor shall be deemed to have satisfied himself before tendering as to the correctness and sufficiency of his tender for the works and of the rates and prices quoted in the Schedule of work/items/quantities or in Bills of Quantities, which rates and prices shall, except as otherwise provided, cover all his obligations under the Contract and all matters and things necessary for proper completion and maintenance of the works.

No extra charges consequent on any misunderstanding or otherwise shall be allowed.

INSPECTION OF DRAWINGS: Before filling in the Tender, the Tenderer will have to check up all Drawings and Schedule of Quantities, and will have to get an immediate clarification from the Architect/Consultant on any point that he feels is vague or uncertain. No claim nor damages or compensation will be entertained on this account.

INTERPRETATION OF CONTRACT DOCUMENTS

- The various sections of tender / contract documents are intended to be complementary to one another.
- In case of a discrepancy in the description of a subject between different sections, the following guidelines shall generally apply.
- Special Conditions of Contract shall override General Conditions of Contract.
- Special specifications shall override General specifications.

Tender Documents for proposed Furnishing & allied works for BO Dhaura Tanda

- For the sole purpose of determination of rates and prices, the Schedule of Quantities including its Preamble shall override Specifications and drawings.
- Detailed drawings shall override General layout drawings.
- Hard copies of the drawings shall override Soft copies.
- Irrespective of these general guidelines the Contractor shall bring any discrepancy he notices immediately to the attention of the Architect/Consultant and shall follow Architect/Consultant's instructions accordingly.

QUALITY ASSURANCE:

The contractor shall prepare a detailed quality assurance Programme to control activities connected with the work to ensure a quality job at various stages

- Planning
- Execution
- Completion
- Post Completion Maintenance

DRAWINGS AND SPECIFICATIONS: The Work shall be carried out to the entire satisfaction of the Bank/Architect/Consultant and in accordance with the signed drawings, specifications, preambles and such further drawings and details as may be provided by the Architect/Consultant and in accordance with such written instructions, directions and explanations as may from time to time be given by the Bank/Architect/Consultant whose decisions as to sufficiency and quality of the work and materials shall be final and binding upon all parties.

No drawing shall be taken as in itself an order for execution unless, in addition to the Architect/Consultants signature, it bears express words stating remark "FOREXECUTION".

The Contractor before the issue of the final certificates shall return all drawings and specifications to the Architect/Consultant. The original copy of contract shall remain in the custody of the Bank and shall be produced by him at his office as and when required.

Any additional prints of drawings if any, required by the contractor will be supplied by the Architect/Consultant on the payment of charges.

Over and above, the Architect/Consultant if requested by the Contractor will issue Soft Copies of the drawings. Necessary protection will be used by the Architect/Consultant to prevent willful editing of such soft copies of the drawings by the contractors. In case of any dispute on between Contractor and Architect Consultant on sanctity of such drawings, hard copies issued by the Architects/Consultants shall prevail and by binding on both the parties.

DIMENSIONS: Figured dimensions are in all cases to be followed and in no case should they be scaled. Large-scale details take precedence over small-scale drawings, in case of the discrepancy; the Contractor is to ask for an explanation before proceeding with the work.

TECHNICAL DATA: Technical Data of relevant items shall be furnished as required.

ACTION WHERE THERE IS NO SPECIFICATION: In the case of any class of work for which there is no Specifications mentioned, the same shall be carried out in accordance with the Indian Standard Specifications subject to the approval of the Architect/Consultant.

EXTENT OF CONTRACT: Items executed shall be complete in all respect with accessories, fittings as required though they may not have been specifically mentioned in the technical specification. All similar standard components/parts of similar items shall be inter-changeable.

APPROVAL OF SUPPLIERS: For all supplies, the names of manufacturers/brands have to be got approved by the Architect/Consultant from the Bank after getting the respective samples first approved by the Architect/Consultant as the case may be. All materials will be of tested quality and as per relevant Indian Standards. In addition to the Test

Tender Documents for proposed Furnishing & allied works for BO Dhaura Tanda

Certificates, mandatory tests will also be done on them by the Architect/Consultant at an approved laboratory at the cost of the contractor immediately as well as at regular frequency laid down in the relevant Indian-standards.

MATERIALS SUPPLIED BY THE BANK: If the Bank supplies any material, the Contractor must satisfy himself that the same conform to the Specifications. If the Contractor has any complaint, about the said materials, or the quality thereof the Contractor before using the said materials inform in writing all their objections to the Bank. Should the Contractor fail to do so, he will be deemed to have satisfied himself as to the quality and the suitability of the said materials for being used in the Contract works and the Contractor will be in the same position as if the Contractor himself had purchased the said material.

MATERIALS AND WORKMANSHIP TO CONFORM TO DESCRIPTION: All materials and workmanship shall, be of the respective kinds specified in the Schedule of Quantities and /or specifications and in accordance with the Architect/Consultants instructions and / or any test of all materials, which the contract provides for, and Architect/Consultant may require. The Contractor shall submit the samples of various materials, to Architect/Consultant/Bank for approval. Further, the contractor shall upon the request of Architect furnish him with all invoices, accounts, receipts and other vouchers to prove that the materials comply therewith. The contractor shall at his own cost arrange for and/or carry out the test of any materials which the Architect may require.

If the Contractor contends that any of the materials, goods or workmanship specified as aforesaid, is unobtainable, he shall submit to the Bank his grounds for his contention, and thereupon the Architect/Consultant/Bank shall verify the same and if required issue necessary clearances and/or instruction in writing.

VARIATIONS

VARIATIONS NOT TO VITIATE CONTRACT: The Contractor shall when directed in writing by the Architect/Consultant to omit from or vary any works shown upon the drawings or described in the specifications or included in the priced Schedule of Quantities, carry out such directions but the Contractor shall not make any alterations in the provisions of the Contract without such authorization or direction in writing from the Architect/Consultant/Bank. No claim for any extra work executed shall be allowed unless the authority of the Architect/Consultant as herein mentioned shall have executed it. No variation, i.e. additions, omissions or substitutions shall vitiate the Contract. No claim for payment for extra work shall be allowed unless the said work shall have been executed under the provisions of Clause "Authorities, Notices, Patent Rights and Royalties", or by the authorities, directions in writing of the Architect/Consultant as herein mentioned. The Architect/Consultant in accordance with the provisions of relevant clauses for variations shall settle the rate of items not included in the Bill of Quantities.

VARIATIONS TO BE APPROVED BY THE BANK: Notwithstanding anything herein contained the rates for such extra/variation items shall be derived as far as possible from like items in the tender, adding/subtracting cost for such variations from like items. In the event of such extra/variation items totally differ in specification/character/nature, rates for such items will be worked out based on prevailing market rates for the ingredients that go into making such of items and finalized by the Architect/Consultant in consultation with the Bank.

EXTRA ITEMS / DEVIATIONS: The Contractor shall not commence work in respect of any extra items/deviations without obtaining the approval of the Architect/Consultant in writing. The Contractor shall immediately submit the rate analysis for such item, with necessary details to support the rate quoted. The Architect/Consultant/Bank shall then settle the rate and necessary certificate based on this shall be given to Bank while incorporating the item in the Interim Bills. Claims for extra/deviated items shall be submitted in the as per specimen copies of Performa included in this tender document that indicate authority/order for such items.

SCHEDULE OF QUANTITIES – VARIATION IN TENDER QUANTITIES: Quantities in this tender are subject to variation by way of addition, reduction or deletions of the items or quantities. No compensation whatsoever will be paid for such variations.

PRICES FOR EXTRAS ETC. – AS CERTAINMENT THEREOF: Should it be found from measurements taken in accordance with the clause on "Measurement of works" that any of the quantities or amounts of works thus ascertained

Tender Documents for proposed Furnishing & allied works for BO Dhaura Tanda

are less or greater than the amounts specified for the works in the priced schedule of quantities and/or that any variation is made from the tender schedule of items by operating Additional items called "Extra Items" or "Substitute Items" in substitution of some tendered items, the rate and valuation thereof, of such items unless previously or otherwise agreed upon, shall be made in accordance with the following rules:-

The net rate or prices in the original Tender shall determine the valuation of the extra quantities where extra quantities for any item are of similar character and executed under similar conditions as the work priced therein. In other words variation in quantities shall be measured and paid at quoted price only.

The net rate or prices in the original Tender shall determine the rate for the items altered, provided if omissions / additions vary the conditions under which any remaining items of works are carried out, the prices for the same shall be valued under (b)hereof.

For extra items/Substitute items where the description of items is different from that of any tendered item, the following method shall hold good.

Where the extra item works are not of similar character and/or executed under condition as aforesaid or where the omissions vary, the conditions under which any remaining items of works are carried out or if the amount of any omission or additions relative to the amount or the whole of the Contract works or to be any part thereof shall be such that in the opinion of the Architect/Consultant the net rate or price contained in the priced Schedule of Quantities or tender or for any item of the works involves loss or expenses beyond that reasonably contemplated by the Contractor or is by reason of such omission or addition rendered unreasonable or inapplicable, the Architect/Consultant shall fix such other rate or price as in the circumstances he shall think reasonable and proper on the basis of actual rate analysis cost of work involved plus fifteen percent (15%) towards Contractor's overheads and profits, which shall be final and binding on the Contractor.

The measurement and valuation in respect of the Contractor shall be completed within the "period of Final Measurement" or within three months of the completion of the Contract works as defined under Clause For "Certificate of Virtual Completion".

DEFECTS

DEFECTS AFTER COMPLETION: Any defect in work and materials or due to unsound installation or other faults which may appear either in the work executed or in materials used within the "Defects Liability Period" stated in the Appendix to General Conditions of Contract here to or if none stated, then for a period of twelve months after the Virtual Completion of the work, arising in the opinion of the Architect/Consultant/Bank from materials or workmanship not being in accordance with the Contract, shall upon the directions and writing of the Architect/Consultant, and within such reasonable time as shall be specified therein, be amended and made good by the Contractor, at his cost unless, the Architect/Consultant in consultation with the Bank shall decide that he ought to be paid for such amending and making good and in case of default the Bank may employ and pay other persons to correct the faults, and all damages, loss and expenses consequent thereon or incidental thereto shall be made good and borne by the Contractor and such damage, loss and expenses shall be recoverable from him by the Bank or may be deducted by the Bank upon the Architect/Consultant's certificate in writing from the amount retained with the Bank vide relevant Clause for "Certificate and Payment" or any money due or that may become due to the Contractor or the Bank may in lieu of such amending and making good by the Contractor, deduct from such money a sum, to be determined by the Architect/Consultant, equivalent to the cost of amending such works, and in the event the said amount retained under relevant clause For "Certificate and Payment " and/or the other sums payable to the Contractor being insufficient, recover the balance from the Contractor.

Tender Documents for proposed Furnishing & allied works for BO Dhaura Tanda

INSPECTION & TESTS

ACCESS FOR INSPECTION: The Contractor is to provide at all times during the progress of the works and the maintenance period proper means of access, ladders, gangways etc. and the necessary attendants to move and adapt the same as directed for the inspection or measurement of the works by the Bank/ Architect/Consultant/Bank or their representatives.

TESTING OF WORKS AND MATERIALS AND PREPARATION OF SAMPLES: The Contractor shall arrange to test materials and/or portions of the works as instructed by Architect/Consultant /Bank to specifications/ ISI standards at his own cost, in order to provide their soundness and efficiency. If after any such test, the work or portions of the works are found to be defective or unsound, the Contractor shall pull down and re-erect the same at his own cost. The Contractor for approval prior to ordering out the same shall submit samples of various materials. Wherever necessary the Contractor shall, at his own cost, prepare samples to indicate the workmanship.

TEST DATA: All the materials shall be tested jointly with the Bank/Architect/Consultant as required by the various sections of the specification and Test Data, shall be furnished as required.

The Contractor shall carry out in the presence of Bank's Representative all specified tests. Such tests shall be carried out at the manufacturer's works or at the works of the Contractor or approved Sub-Contractor.

The Contractor shall then forward all the relevant copies of Tests so performed in 3 sets for the record of the Bank/Architect/Consultant. No compensation of any kind will be payable to the Contractor for carrying out such tests.

The Contractor shall give clear 15 days notice in writing for all such tests to be carried out at relevant place of Manufacture, Works, Sub- works etc.

COST CONTROL QUANTITIES SCHEDULE OF QUANTITIES: The Schedule of the Quantities unless otherwise stated shall be deemed to have been prepared in accordance with the standard procedure of the Architect/Consultant, and shall be considered to be approximate and no liability shall attach to the Architect/Consultant /Bank for any error that may be discovered therein.

SUFFICIENCY OF SCHEDULE OF QUANTITIES: The Contractor shall be deemed to have satisfied himself before tendering as to the correctness and sufficiency of his tender for the works and of the prices stated in the Schedule of Quantities and/or the Schedule of Rates and Prices, which rates and prices shall cover all his obligations under the Contract, and all matters and things necessary for the proper completion of the works.

The Contractor shall check all the Air-Conditioning system drawings and details prepared by the Architect/Consultant and report errors if any in the drawings or details.

ERRORS IN SCHEDULE OF QUANTITIES: Should any error appear in the Schedule of Quantities, other than in the Contractor's prices and calculations, it shall be rectified, and such rectification shall not vitiate the Contract but shall constitute a variation of the Contract and shall be dealt with as an authorized extra or deduction

PRIME COST & PROVISIONAL SUMS: Where "Prime cost"(p.c.) prices or provisional sums of moneys are provided for any goods or work in the specification / Schedule of Quantities the same amount will be exclusive of any trade discounts or allowances, cash- discounts, profit, carriage and fixing which the contractor may require.

All goods or work for which prime cost prices or provisional sums of money are provided may be selected or ordered from any manufacturers or firms at the discretion of the Architect of the Bank and the Bank reserves to himself the right of paying direct for any such good or Work and deducting the said prices and sums from the amount of contract. Should any good or work for which prime cost prices or provisional sums are provided or portions of the same be not required, such prices of sums, together with the profits allowed for the same and such additional amounts as the contractor may have allowed for carriage and packing will be deducted in full from the contract, whether the goods be ordered by the

Tender Documents for proposed Furnishing & allied works for BO Dhaura Tanda

contractor or otherwise, the contractor shall at his own cost fix the same if called upon to do so and the contractor shall also receive and sing for such goods and be responsible for their safe custody from the date of their delivery upon the works.

In cases in which the provisional quantities of materials are contained in the contract, the contractor shall provide such material to such amounts or to greater or less amounts as the Architect shall direct in writing as the net rates at which he shall have priced such items in his schedule of Quantities, should however any such items be entirely omitted, which omission shall be at the Architect's discretion, no profit or such items shall be allowed to the contractor.

No prime costs sum or sums (or any portion thereof) shall be included in any certificate for payment to the contractor until the contractor to the Architect has produced the receipted accounts relating to them. Such accounts shall show all discounts and any sum or sums in respect of such discounts shall be treated as trade discount provided always that should the contractor in lieu of producing such receipted accounts request the Architect in writing to issue a Certificate on the Bank for such sum or sums due either on account in settlement to a sub-contractor direct, the architect shall, upon satisfying himself that the sub-contractor is entitled to the same, so issue the certificate, and such sum or sums shall be deducted from the amount of the contractor at the settlement of accounts and any profit or further sum which the contractor is property entitled in respect of such sub-contract, and which is in conformity with the terms of the contract, shall be allowed to the contractor at the settlement of accounts as though the amount of such certificate to the sub-contractor had been included in a certificate drawn in favor of the contractor.

If the Contractor neither produces the receipt nor gives authority to the Architect to issue a certificate in favor of such sub-contractor directly, the Architect shall, upon giving the contractor seven days notice in writing of his intentions to do so, issue to the Sub- contractor such Certificate directly on the Bank and obtain the receipt from the Sub- contractor, which receipt shall be deemed a discharge for the amount of such certificate as though given by the Contractor. In the event of such default on the part of the Contractor, he shall not be allowed any profit he may have added in the Schedule of Quantities upon such Such-contract.

The exercise of the option before referred to by the contractor and the issue of certificate as before described to Sub-contractors upon the Contractor's request on the issue to sub-contractor direct of certificate by the Architect shall not, however, relieve the Contractor from any of the liabilities in respect of insufficient, faulty or in completed work or the Sub-contractor for which he may be liable under the terms of the contract.

If any provisional items are provided for work of any nature usually carried out by the contractor in the ordinary course of his business, the Bank shall give the contractor an opportunity of tendering for the same without prejudice to the Bank's right to reject the lowest or any tender.

पी.एस.बी

MEASUREMENTS

MEASUREMENT OF WORKS: The Architect/Consultant shall from time to time intimate the Contractor that he requires the works to be measured and the Contractor shall forthwith attend or send a qualified agent to assist the Architect/Consultant's representative in taking such measurements and calculations and to furnish all particulars or give all assistance required by either of them. Should the Contractor omit to attend or neglect or omit to send such agent, then the measurements taken by the Architect/Consultant or approved by him shall be taken to be the correct measurements. The works shall be measured according to the mode of measurements specified in the Contract documents and, where no mode is specified, as per the latest edition of relevant I.S. Codes.

A certain percentage of measurements will be checked/test checked by the Bank as the case may be for each trade, and for this the contractor has to render all necessary assistance and co-operation.

The Contractor or his Agent may at the time of measurement take such notes and measurements as he may require.

All authorized extra works, omissions and all variations made without the Architect/Consultant's knowledge, but if subsequently sanctioned by the Bank in writing, shall be included in such measurements.

MODE OF MEASUREMENT

- a) The mode of measurement for this contract shall be on item rate basis and shall include all quantities specified in the Schedule of Quantities of this tender/ contract. It shall be further deemed that all variation and deviations if specifically agreed to in writings shall also form part of this tender/ contract and shall be subject to measurements. All payments released to the Contractor shall be subject to verification of quantities on the basis of mode of measurements herein stated.
- b) If the mode of measurement for any or all item is not specified in the contract, latest relevant IS. Code will prevail.
- c) The Contractor shall give due notice to the Bank/ Architect/Consultant in writing whenever any work is to be concealed or made inaccessible, in order that the work may be inspected and correct measurements are recorded before such concealment, in default whereof the same shall be at the option of the Architect/Consultant/ Bank to either open up for measurement at the Contractor's expense or no allowance shall be made for such work.

PAYMENTS & CERTIFICATION

CERTIFICATE & PAYMENT: No interim payment to be released until the completion of work. Only one single payment will be released after the submission of completion certificate by the architect.

The Architect/Consultant may by any Certificate make any correction in any previous certificates, which shall have been issued by him. In the event if it comes to the Bank's notice any omission or corrections required in bill certified by Architect/Consultant, the Bank shall effect necessary corrections and the contractor shall be bound to accept the same. This certificate is particularly essential for settlement and payment of the Final Bill.

Note: If any part/reduced rate is proposed by the Contractor (recommended by Architect/Consultant) the same should be brought in the notice of the bank along with the reasons.

The Bank shall carry out test checking of measurement as and when required.

The Contractor shall submit the final bill within One month of Virtual Completion Certificate received by the Contractor duly endorsed by the Architect/Consultant and the Architect, and such bill shall be settled and certified for payment by the Architect/Consultant within four weeks of the receipt of the Certificate of payment from the Architect/Consultant.

The Bank shall make payment upon the Architect/Consultant's Final Certificate within a period of Four weeks from the date of its receipt and acceptance of the certificate.

The Contractor shall submit Performa (A) and (B) serially numbered with dates for all extra/ deviated items of work.

Contractor shall, without fail, submit along with his R.A. Bills/ Final Bills test certificates as specified.

Running Account Bills (R.A. Bills)/Final Bill received without the test certificates duly approved by Architect/Consultant shall be returned to the Contractor for the reason of the same being not submitted duly.

Delayed Payment: Any amounts payable by the Bank to the Contractor in pursuance of any Certificate given by the Architect hereunder shall if not paid within the "Period of honoring certificates" named in the Appendix carry interest at the rate named in the Appendix as the "Rate of interest for delayed payment" from the date upon which such sum ought to have been paid by the Bank, until payment.

Tender Documents for proposed Furnishing & allied works for BO Dhaura Tanda

CERTIFICATE FOR PAYMENT TO CONTRACTOR: The Contractor's bills will be submitted to Bank through the Architect/Consultant for payment as per Performa enclosed for Final Bill Certificate. The Architect/Consultant in confirmation that the work has been carried out satisfactorily as per detailed drawings and specifications will endorse and certify the bill.

CERTIFICATE OF VIRTUAL COMPLETION OF WORKS: a) The Contractor shall report in writing to the Architect/Consultant, in the form of a Certificate as per Performa 'D' annexed hereto as and when the works are completed in all respects. The Architect/Consultant shall after the verification of the works and in Consultation with Bank issue to the Contractor a certificate to be called "Virtual Completion Certificate", a copy whereof shall be submitted to the Bank to enable them to take possession of the completed works.

b) The works shall not be considered as completed till the Architect certifies in writing that all the work including those mentioned in the snag list prepared jointly with Architect/Consultant/Bank prior to the acceptance of the Virtual Completion. The defect liability period shall commence only from the date of issue of such certificate.

LIEN ON SUMS PAYABLE TO THE CONTRACTORS: Any sums of money due and payable to the Contractor including any deposits returnable to them under this Contract may be withheld or retained by the Bank, against any claim of the Bank against the contractor in respect of any sums of money due under this contract or any other contract made by the contractor with the Bank, but limited to the amount of Bank's claim and the Bank shall always have a lien upon the money so withheld or retained as such by the Bank until appropriated towards such claim. The contractor shall not be entitled to claim any interest or damages whatsoever on such retained or appropriated sum.

PROJECT MANAGEMENT PROGRAM OF WORK: The Tenderer shall, along with his bid, submit a schedule for completion of work, either in the form of a CPM Net Work or in the form of a bar chart, showing how he proposes to complete the works. This program shall be prepared in sufficient detail and shall indicate, among other things, the following details on a week to week basis (for each week).

- Quantum of work under each major item of work that would be carried out.
- List of Sub-contractors.
- Amount of resources that would be deployed (e.g. materials, skilled/unskilled labour, equipment etc.)
- Schedule of delivery of materials to site.
- Approximate value of work contemplated to be completed each week.
- Schedule and manner in which details or materials (to be issued by the Bank) are required from the Architect/Consultant/Bank
- Time periods allowed for other agencies' work,
- Various milestones to be achieved.

This program suitably amended after discussions with the Architect/Consultant shall become binding on the Contractor. However, during the execution of the project, should it become necessary, in the opinion of the Architect/Consultant to reschedule some of the activities, the Contractor shall do so at no extra cost and/or without any other claim. Acceptance of a bidder's tender does not necessarily imply acceptance of the schedule submitted and the Architect/Consultant/Bank reserve the right to modify/amend this schedule to suit the overall project schedule which will be binding on the Contractor at no extra cost to the Bank.

COMMENCEMENT OF WORK: The contractor shall be allowed admittance to the site on the "date of Commencement" stated in the Appendix and on submission of the valid tamper-proof photo Identity Card (and/or in any other form), duly endorsed by the Contractor, for all their labour, and staff in accordance with the Banks prevailing security requirement.

The Contractor shall commence work forthwith or within the mobilization period defined in the Work order or within the maximum period of 15 days, whichever is earlier, from the date of receipt of Work Order and shall regularly proceed with the work and ensure to complete same on or before the "day of Completion" stated in the Appendix subject nevertheless to the provisions for extension of time hereinafter contained. Until the site is partly / fully handed over to the

Tender Documents for proposed Furnishing & allied works for BO Dhaura Tanda

Contractor, the commencement of work shall include off-site activities including planning, procurement of materials shop drawings, manufacture/fabrication, interaction with Architect/Consultant / other contractors etc.

DATE OF COMPLETION:

- The entire work shall be completed in all respects including testing within the period stipulated in this Tender form.
- Time is the essence of the Contract.
- The work shall not be considered as complete until the Architect/Consultant have certified virtual completion in writing. The defects liability period shall commence from the date of such certificate.
- During the period of Contract, the Contractor shall maintain progress on the basis of the program initially agreed to by Bank / Architect/Consultant and later updated from time to time in consultation with Bank/Architect/Consultant to suit the overall project schedule and prevailing site conditions.

DELAY AND EXTENSION OF TIME:

If in the opinion of the Bank the works be delayed

- By force majeure or
- By reason of any exceptionally inclement weather or
- By reason of proceedings taken or threatened by the dispute with adjoining or neighboring Banks or public authorities arising otherwise than through the Contractor's own default
- By the works or delays of other Contractors or tradesmen engaged or nominated by the Bank or the Architect/Consultant and not referred to in the Schedule of Quantities and/or Specifications or
- By reason of the Architect/Consultant's instructions.
- By reason of civil commotion, legal combination of strike or lock-out affecting any of the building traders or in consequence of the Contractor not having received in due time necessary instructions from the Architect/Consultant for which he shall have specifically applied in writing, ahead of time, giving the Consultant reasonable time to prepare such instructions, the Bank shall make a fair and reasonable extension of time for completion of the Contract works. In case of such strike or lock-out, the Contractor shall, as soon as may be, give written notice thereof to the Architect/Consultant, but the Contractor shall nevertheless constantly use his endeavors to prevent delay and shall do all that may reasonably be required to the satisfaction of the Architect/Consultant to proceed with the work.

The Contractor shall proactively take all practicable steps to avoid or reduce any delay in the execution and completion of the works arising out of

- Force Majeure
- Exceptionally inclement weather
- Loss and damage by fire and earthquake
- Civil commotion, lockout, strike etc.
- Delay on the part of the nominated Sub-Contractor or nominated supplier.
- Delay on the part of the other Contractors employed by the Bank.

SUSPENSION OF WORKS: The Architect/Consultant may in an extreme case and in prior consultation with the Bank suspend works if the quality or safety of the works are likely to be compromised due to heavy rains, natural calamities etc. The Architect/Consultant may grant such extension of time with the approval of the Bank as may be justified by such a delay in the works. The Contractor shall not be entitled to any compensation on account of such delay.

WORK AT NIGHT: If the Contractor is required to work at night in order to complete the work within the Time Schedule, the Contractor shall provide and maintain at his own cost sufficient lights to enable the work to proceed satisfactorily without danger. Approaches to the site also shall be sufficiently lighted by the Contractor. No extra payments will be made for night work. Prior intimation and approval should also be taken from Architect/Consultant.

WORK ON HOLIDAY: No work shall be done on national holidays that may be notified by the Bank without the specific sanction in writing of the Bank/ Architect/Consultant.

Tender Documents for proposed Furnishing & allied works for BO Dhaura Tanda

INDEPENDENT CONTRACTOR: The Contractor agrees to perform this Contract as an independent Contractor and not as a sub- Contractor, agent or Employee of the Bank.

ASSIGNMENT OR SUB-LETTING: The whole of the works included in the Contract shall be executed by the Contractor and the Contractor shall not directly or indirectly transfer, assign or under-let the Contract or any part/ share thereof or interest therein, nor shall he take a new partner, without the written consent of the Architect/Consultant/ Bank and no undertaking shall relieve the Contractor from the full and entire responsibility of the Contract or from active superintendence of the works during their progress. Nominated Sub-contractors: All specialists, merchants, tradesmen and others executing any work or supplying and fixing any goods for which prime cost prices or provisional sums are included in the Schedule of Quantities and/or Specifications who may be nominated or selected by the Architect are hereby declared to be Sub- contractors employed by the Contractor and are herein referred to as nominated Sub-contractors. No nominated Sub- contractor shall be employed on or in connection with the works against whom the contractor shall make reasonable objection or (Save where in the Architect and Contractor shall otherwise agree) who will not enter into contract provided:- - That the nominated Sub-contractor shall indemnify the contractor against the same obligations in respect of the Sub- contract as the contractor is under in respect of this contract. - That the nominated Sub-contractor shall indemnify the contractor against claims in respect of any negligence by the Sub-contractor, his servants or agents or any misuse by him or them of any scaffolding or other plant, the property of the contractor or under any Workman's Compensation Act in force. - Payment shall be made to the nominated Sub-contractor within 15 days of his receipt of the Architect's certificate provided that before any certificate is issued the contractor shall upon request furnish to the Architect proof that all nominated Sub-contractor's accounts included in previous certificates have been duly discharged; in default whereof the Bank may pay the same upon a certificate from the Architect and deduct the amount thereof from any sums due to the contractor.

OBTAINING INFORMATION: No claim by the Contractor for additional payment will be entertained which is consequent upon failure on his part to obtain correct information as to any matter affecting the execution of the works, nor will any misunderstanding or the obtaining of incorrect information or the failure to obtain correct information relieve him from any risks or from the entire responsibility for the fulfillment of the contract.

THE SETTING OUT: The Contractor shall at his own expense, set out the works accurately in accordance with the plans. The Contractor shall be solely responsible for the true and perfect setting out of the works, and for the correctness of the position, levels, dimensions and alignment of all parts thereof. If at any time any errors shall appear during the progress or on completion of any part of the work, the Contractor shall at his own cost rectify such error if called upon to the satisfaction of the Architect/Consultant. The Bank and/or its representatives shall from time to time inspect the work but such inspections shall not exonerate the Contractor in any way from his obligations to remedy any defects that may be found to exist at any stage of the work or after the same is completed.

PERFORMANCE

- i) The Contractor shall be fully and solely responsible for proper, safe and efficient design and performance of his equipment and installation, in conformity with drawings and parameters and specifications stipulated in the Contract documents.
- ii) In case the Contractor finds that anything contained in drawings, specifications or given parameters will not ensure such performance and compliance with best trade practices and codes, rules and regulations laid down by Authorities, he shall bring such matters to the attention of the Architect/Consultant and shall follow their instructions.
- iii) The contractor shall also guarantee that the performance of the various materials and items individually shall not be less than specified ratings when working under operating conditions given for the respective items.

EXECUTION OF WORK:

- a) The whole of the work as described in the Contract (including the Schedule of Quantities, Preamble, the specifications and all drawing pertaining thereto and as advised by the Architect/Consultant from time to time is to be carried out and completed in all its parts to the entire satisfaction of the Architect/Consultant. Any minor details of manufacture,

Tender Documents for proposed Furnishing & allied works for BO Dhaura Tanda

fabrication and installation which are obviously and fairly intended, or which may not have been definitely referred to in this Contract, but which are usual in sound Security and Surveillance systems execution practice and essential to the work, are to be included in the Contract. Rates quoted in the Schedules shall be inclusive of all freights, taxes, such as Octroi, Sales Tax, Excise Tax, Work Contract Tax, Royalties, VAT etc. as well as transportation so as to execute the Contract as per the rules and regulations of Local Bodies, State Government and the Government of India, and to the full intent of tender documents.

Following shall be deemed to be provided for in the quoted rates:

- Labour for constructing, fixing, finishing, carrying, cleaning, making good etc.
- Framework, ladders, ropes, nails, spikes, tools, material and workmanlike protection from weather, temporary supports.
- Covering for the works during inclement weather or strikes or whenever directed, as necessary.
- All temporary canvas, lights, tarpaulin, barricades water- sheets etc.
- All such temporary weatherproof sheds at such places and in a manner approved by the Architect/Consultant for the storage and protection of materials against the effects of Sun or rain.
- All minor civil works like breaking and making good of masonry walls to original condition for passage of cables, cable trays etc.
- Provision of necessary frames (MS/wooden) for dressing up of wall/RCC openings and for installation of Fans etc. if instructed by Architect/Consultant. Drawings for framework to be got approved from Architect/Consultant.
- The rate quoted by the Tenderer in the schedule of probable quantities will be deemed to be for the finished work inclusive of the cost of providing the above items.

CONTRACTOR TO PROVIDE EVERYTHING NECESSARY: The Contractor shall provide everything necessary for the proper execution of the works according to the true intent and meaning of the Drawings, Specifications and Schedule of Quantities taken together whether the same may or may not be particularly shown or described therein, provided that the same can reasonably be inferred where from and if the Contractor finds any discrepancy in the Drawings or between the Drawings, Specifications and Schedule of Quantities he shall immediately refer the same in writing to the Architect / Consultant, who shall decide which shall be followed, and his decision shall be final and binding on all parties. The Contractor shall provide ground for himself and fresh water and power for carrying out of the works at his own cost. - The Bank shall not charge the Contractor for his own un-rented ground but shall on no account be responsible for the expenses incurred by the Contractor for hired ground. - The Contractor shall provide and maintain all measuring and testing instruments at all times for properly carrying out the work and for the use of the Architect/Consultant /Bank, including providing skilled attendants as required. - The Contractor shall supply, fix and maintain at his cost during the execution of any works, all the necessary equipment, materials and lighting required by night and as well as by day for proper execution of work. The contractor shall take down and remove any or all such unwanted waste materials, debris etc. as occasion shall require or when ordered to do so, and shall fully reinstate and make good all matters and things described during the execution of the works, to the satisfaction of the Architect/Consultant/ Bank

FACILITIES TO OTHER CONTRACTORS: The Contractor shall give full facilities and co-operation to other Contractors employed by the Bank and shall afford them reasonable opportunity for the execution of their works and for properly connecting and co-coordinating their works with the work of the other Contractors. The decision of the Architect/Consultant on any points of dispute between the various Contractors shall be final and binding on all parties concerned.

STORES AT SITE: The Contractor shall be allotted space / existing rooms on site subject to availability. The Contractor shall make his own arrangements to enclose, secure and guard the space allotted to him. Wherever there may be materials, which are likely to deteriorate by the action of the sun, rain or other elements, all such materials, tools etc shall be duly protected by the Tenderer from damage by weather or any other cause. All such stores and yards shall be cleared away and ground left in good and proper order, on completion of this Contract unless otherwise expressly mentioned herein.

ELECTRIC POWER FOR INSTALLATION: The Contractor shall be given a temporary electrical connection at one location at or below ground level to be decided by the Bank. The Contractor shall, at his own cost, provide a sub-meter,

Tender Documents for proposed Furnishing & allied works for BO Dhaura Tanda

cabling and wiring and switchboards complying with all laws, rules and regulations in force and ensuring the safety of everyone working or visiting onsite. The Contractor shall regularly reimburse cost for electricity consumed to the Main Contractor at the same tariff rates as charged by the Electric Supply Company.

FOR REMOVAL OF ALL OFFENSIVE MATTERS: All soil, filth or other matter of an offensive nature taken out of any trench, sewer, drain or other place shall not be deposited on the surface, but shall be at once carried away by the Contractor and disposed off as per the rules and regulations of the Local Authorities concerned.

UNFIXED MATERIALS: When any materials intended for the works shall have been placed at site by the Contractor, such materials shall not be removed there from (except for the purpose of being used on the works) without the written authority of the Architect/Consultant and when the Contractor shall have received payment in respect of any Certificate in which the Architect/Consultant shall have stated that he has taken into account the value of such unfixed materials on the works, such materials shall become the property of the Bank, and the Contractor shall be liable for any loss or damage to any such materials.

REMOVAL OF IMPROPER WORK AND MATERIALS: The Architect/Consultant shall, during the progress of the works, have power to order in writing from time to time the removal from the works, within such reasonable time as may be specified in the order, of any materials which, in the opinion of the Architect/Consultant are not in accordance with the specifications or the instructions of the Architect/Consultant and the substitution of proper materials and the removal and proper re- execution of any work, which has been executed with materials or workmanship, not in accordance with the Drawings and Specifications or instructions, and the Contractor shall forthwith carry out such order at his own cost. In case of default on the part of the Contractor to carry out such order the Bank shall have power to employ and pay other persons to carry out the same and all expenses consequent there on or incidental thereto shall be borne by the Contractor, and shall be recoverable from him on behalf of the Bank or may be deducted by the Architect/Consultant from any money due or that may become due to the Contractor.

If the correcting works are not done in accordance with the Contract the Architect/Consultant, in consultation with the Bank, may allow such work to be got done through other parties at Contractors risk and cost and in that case they may make allowance for the difference in value together with such further allowance for damages to the Bank as in their opinion may be reasonable.

CLEARING THE SITE OF WORKS: The Contractor shall clear site of works as per the instructions of the Architect/Consultant. The site of works shall be cleared of all men, materials, sheds, etc. belonging to the Contractor. The site shall be delivered in a clean and neat condition as required by the Architect/Consultant within a period of one week after the job is completed. In case of failure by the Contractor, the Bank under advice of the Architect/Consultant will have the right to get the site cleared at the risk and cost of the Contractor to the satisfaction of the Architect/Consultant.

OCCUPATION OF PARTIALLY COMPLETED WORKS BY THE BANK: The Bank shall be entitled to and at liberty to occupy even the partially completed works or any portion thereof by themselves or through their agents and servants if they so desire, in which event, necessary extension of time on this account for completing the works shall however be granted to the Contractor, but he shall have no claim for any compensation whatsoever due to the delay involved in completing works. Both the Bank and the Contractor will work out the repercussions on the insurance Clause mentioned afore to mutual satisfaction safeguarding each other's interest.

PREPARATION FOR OCCUPATION AND USE ON COMPLETION: On completion of the work, the Contractor shall inform the Architect/Consultant in writing that he has finished the work and it is ready for the Architect/Consultant's/Bank's inspection. The Contractor shall clean all his works and all the rooms under his charge. He will leave the entire works neat and clean and ready for occupation and to the satisfaction of the Architect/Consultant.

KEEPING THE AREAS AND ACCESS ROADS CLEAN:

1. The Contractor shall be required to maintain the site and the building areas in a neat and clean condition at all times to the satisfaction of the Architect/Consultant. Debris to be removed every 2days.

Tender Documents for proposed Furnishing & allied works for BO Dhaura Tanda

2. The Contractor shall also be required to keep all access Roads to the site and within the site free from all obstructions, material droppings etc. to the satisfaction of the Consultant and local authorities.

COVERING UP OF WORKS: The Contractor shall cover up and protect the works from the weather and shall suspend all wet operations during weather which, in the opinion of Architect/Consultant, will be detrimental to the works.

MEASUREMENT TO BE RECORDED BEFORE WORK IS COVERED UP: The Contractor shall take joint measurements with the Architect/Consultant before covering up or otherwise placing beyond the reach of measurement any items of work. Should the Contractor neglect to do so, the same shall be uncovered at the Contractor's expense or in default thereof, no payment or allowance shall be made for such work or the materials with which the same was executed.

SITE SURVEY: On award of the works, the Contractor shall immediately survey the complete site and record his findings on civil works and services connected with his works and submit the report in duplicate. No extra payment shall be made for this work.

LABOUR HUTMENTS: The Contractor shall not be allowed to put up any hutment / temporary structure of accommodating his labour/staff. He shall be required to make these arrangements elsewhere at his own cost. However, if the rules of local authorities so permit and subject to the contractor arranging for such permission, some space at site which will not come in the way of the permanent construction, temporary construction facilities and offices may be provided to the contractor at the discretion of the Bank for essential/core staff engaged on emergency or essential services round the clock work with proper sanitary facilities.

STAFF MANAGEMENT INFORMATION TO BE SUPPLIED BY THE CONTRACTOR: - The Contractor shall furnish the Bank the following: - Detailed industrial statistics regarding the labour employed by him etc. - The power of Attorney, name and signature of his authorized representative who will be in charge for the execution of the work. - A list of technically qualified persons Employed by him for the execution of the work. - The total quantity and quality of materials used for the work.

APPOINTMENT OF ENGINEERS:

a) The Contractor shall appoint a Senior Engineer to the satisfaction of the Architect/Consultant/Bank. The Architect/Consultant/Bank shall be entitled to approve or disapprove without assigning reasons the appointment of such Engineer proposed by the Contractor. This condition shall be reckoned as being the essence of the contract and its breach shall make the Contract revocable at the option of the Bank. The Senior Engineer shall be assisted by a number of other Engineer sand Supervisors in the respective disciplines as required for the smooth and satisfactory execution of the work.

b) The Engineer so appointed shall be available at all times when required by Architect/Consultant/Bank to attend all site/office meetings to discuss all aspects of the Contract including design, administration, planning, fabrication, installation, commissioning, testing and defects liability maintenance as well as site co-ordination with all Contractors/Agencies.

c) The Senior Engineer shall not be required to be present full time at site but shall be available at all times when required by Architect/Consultant to attend site/office meetings to discuss any aspect of the contract.

SITE ENGINEER: Successful Tenderer will have to, before receiving work order, select suitable Engineer to be interviewed by Architect/Consultant/Bank. It will be the responsibility of the selected engineer to ensure that minutes of site meetings are maintained up-to-date. Contractors have to be up-to-date for each site meeting to be held.

CONTRACTOR'S SUPERINTENDENCE & REPRESENTATIVE ON WORKS: The Contractor shall give all necessary personal superintendence during the execution of the works and as long thereafter as the Architect/Consultant may consider it necessary until the expiration of the "Defects Liability Period" stated in the Appendix hereto.

Tender Documents for proposed Furnishing & allied works for BO Dhaura Tanda

The Contractor shall maintain and be represented on site, at all times while the work is in progress, by a responsible and efficient Engineer In-charge, approved by the Architect/Consultant and who must thoroughly understand all the trades entailed and be constantly in attendance, while the men are at work. Any directions, explanations instructions or notices given by the Architect/Consultant to such Engineer In-charge shall be deemed to be given to the Contractor and shall be binding as such on the Contractor. The Engineer-in-charge shall be thoroughly conversant with the English Language and should be able to read, write and speak English.

DISMISSAL OF WORKMEN: The Contractor shall on the request of the Architect/Consultant/ Bank immediately dismiss from the works any person employed thereon who may, in the opinion of the Architect/Consultant, be unsuitable or incompetent or who may misconduct himself and such person shall not again be employed or allowed on the works without the permission of the Architect/Consultant/ Bank.

OTHER PERSONS ENGAGED BY THE BANK: The Bank reserves the right to use the premises and any portion of the site for the execution of any work i.e. not included in this Contract which he may desire to have carried out by other persons, and the Contractor has to allow all reasonable facilities for the execution of such work, but is not required to provide any plant or material for the execution of such work, except by special arrangement with the Bank. Such work shall be carried out in such a manner as not to impede the progress of the works included in the Contract, and the Contractor shall not be responsible for any damage or delay which may happen to or be occasioned by such work.

INSTRUCTIONS DURING EXECUTION

On the advice of the Bank, the consultants may issue further drawings and written instructions, details, directions and explanations collectively referred to as "Site instruction" in regard to:

- The variations/modification of the design and the quality or quantity of works as addition or omission or substitution of any works therein.
- Any discrepancies in the drawings or between the schedule of quantities and/or specifications and/or drawings.
- Removal from the site any material brought by the contractor and substitution of any other materials therefore.
- The dismissal or removal from work of any person employed thereupon.
- Removal/re-examination of any works executed in case of doubt of any nature.
- Opening up for inspection of any work covered up without proper tests by the Architect/Consultant.
- Oversight on the part of the Architect/Consultant/his assistant to disapprove any defective work or material shall not prejudice the Bank/Consultant, thereafter to disapprove such work or materials and to order pulling down, replacement, removal breaking up or reconstruction.
- The Contractor shall make his own arrangement for the engagement of all labour and shall be responsible for regulating their service conditions, work conditions in conformity with all Acts, Regulations, Rules or order of competent authority under relevant laws in force during the pendency of the contract.
- Contractor shall indemnify the Bank from all claims relating to the workers/ staff/ sub- contractors, Salaries, Wages, Overtime, Leave, Provident Fund, Medical facilities, gratuity, Bonus or any other claim as applicable and stipulated in any statutory provisions, rules or order of competent authority.
- All materials so far as procurable shall be of the reputed make in the category of manufacture and bear the stamp of quality of the Bureau Standards wherever applicable. The contractor shall furnish documentary proof, test certificates and guarantees as relevant to such materials from manufacturers, which shall match with the date of procurement.
- ALL necessary works like staging, ladders, platforms, double staging etc. all are required for proper - Providing at exact locations and to exact sizes pre-designated openings.
- Bailing out, pumping out or otherwise removing all water, which may accumulate from all causes. Sampling and testing of any other material during the course of work as and when directed.

SAFETY MANAGEMENT

REPORTING OF ACCIDENTS TO LABOUR: The Contractor shall be responsible for the safety of persons employed by him on the works and shall report serious accidents to any of them, however and wherever occurring on the

Tender Documents for proposed Furnishing & allied works for BO Dhaura Tanda

works, to the Architect/Consultant and Bank who may make every arrangement to render all possible assistance. This shall be without prejudice to the responsibility of the Contractor under the Insurance Clause of the General Conditions.

Use of Explosives: Explosives shall not be used on the works by the contractor without the written permission of the Architect/Consultant and then only in the manner and to the extent to which he has prescribed. When explosives are used, the same shall be stored in a special magazine to be provided by and at the cost of the contractor, who shall be liable for all damages, loss or injury for non-compliance with all the statutory obligations.

SAFETY CODES: Scaffolds Suitable scaffolds shall be provided for workmen for all works that cannot safely be done from the ground, or from solid construction except in the case of short duration work, which can be done safely from ladders. When a ladder is used, it shall be of rigid construction made either of good quality wood or steel. The steps shall have a minimum width of 450mm and a maximum rise of 300mm. Suitable hand holds of good quality wood or steel shall be provided and the ladder shall be given an inclination not steeper than 1/4 to 1 (1/4 horizontal to 1 vertical)

Scaffolding or staging more than 4 m. above the ground floor, swung or suspended from an overhead support or erected with stationary support shall have a guard rail properly bolted, braced or otherwise secured, at least 1m above the floor or platform of such scaffolding or staging and extending along the entire length of the outside and ends thereof with only such openings as may be necessary for the delivery of materials. Such scaffolding or staging shall be fastened to prevent it from swaying from the building or structure.

Working platforms, gangways and stairway shall be so constructed that they do not sag unduly or unequally and if the height of the platform, gangway or stairway is more than 4m. Above ground level or floor level, they shall be closely boarded and shall have adequate width and be suitably fenced as described in (ii) above.

Providing suitable fencing shall provide every opening in the floor of a building or in a working platform with suitable means to prevent the fall of persons or materials or railing whose minimum height shall be one mt. Wherever there are open excavations in ground, they shall be fenced off by suitable railing and danger signals installed at night so as to prevent persons slipping into excavations.

Safe means of access shall be provided to all working places. Every ladder shall be securely fixed. No portable single ladder shall be over 9m. in length while the width between said rails in rung ladder shall in no case be less than 2120mm for ladder up to and including 3 m. in length. For longer ladders this width shall be increased at-least 20mm. for each additional meter of length.

A sketch of the ladders and scaffolds proposed to be used shall be prepared and approval of the Engineer obtained prior to construction.

All scaffolds, ladders and other safety devices mentioned or described herein shall be maintained in safe condition and no scaffold, ladder or equipment shall be altered or removed while it is in use.

OTHER SAFETY MEASURES:

a) All personnel of the Contractor working within the site shall be provided with safety helmets. All welders shall wear welding goggles while doing welding work and all metal workers shall be provided with safety gloves. Persons employed on metal cutting and grinding shall wear safety glasses.

b) Adequate precautions shall be taken to prevent danger from electrical equipment. No materials on any of the sites of work shall be so stacked or placed as to cause danger or inconvenience to any person or the public.

PERSONAL SAFETY EQUIPMENTS:

a) All necessary personnel safety equipment as considered adequate by the Engineer should be kept available for the use of the persons employed on the site and maintained in a condition suitable for immediate use, and the Contractor should take adequate steps to ensure proper use of equipment by those concerned.

Tender Documents for proposed Furnishing & allied works for BO Dhaura Tanda

b) Workers employed on mixing asphalt materials, cement and lime mortar shall be provided footwear and protective goggles.

c) Those engaged in white washing and mixing or stacking of cement bags or any materials, which are injurious to the eyes, shall be provided with protective goggles.

d) Those engaged in welding works shall be provided with welder's protective eye sight lids. Stonebreakers shall be provided with protective goggles and protective clothing and seated at sufficiently safe intervals.

When workers are employed in sewers and manholes which are in use, the Contractor shall ensure that the manhole covers are opened and are ventilated at least for an hour before the workers are allowed to get into manholes and the manholes so opened shall be cordoned off with suitable railing and provided with warning signals or boards to prevent accident to the public.

The Contractor shall not employ men below the age of 18 years and women on the work of painting with products containing lead in any form. Whenever men above the age of 18 are employed on the work of lead painting, the following precautions should be taken:

No paint containing lead or lead products shall be used except in the form of paste or ready-made paint. Suitable face masks should be supplied for use by the workers when paint is applied in the form of spray or a surface having lead paint dry rubbed and scraped.

The Contractor to the workmen shall supply overalls and adequate facilities shall be provided to enable the working painters to wash during the cessation of the work.

When the work is done near any public place where there is risk of drowning all necessary equipments should be provided and kept ready for use and all necessary steps taken for prompt rescue of any person in danger and adequate provision should be made for prompt first aid treatment of all injuries likely to be sustained during the course of the work.

Adequate washing facilities should be provided at or near places of work.

HOISTING MACHINES

- Use of hoisting machines and tackle including their attachments anchorage and supports shall conform to the following standards or conditions:

- This shall be of good mechanical constructions, sound material and adequate strength and free from patent defect and shall be kept in good repair and in good working order.

- Every rope used in hoisting or lowering materials or as means of suspension shall be of durable quality and adequate strength and free from patent defects. - Every crane driver or hoisting appliance operator shall be properly qualified and no person under the age of 21 years shall be in charge of any hoisting machine including any scaffolding winch or give signals to operator.

- In case of every hoisting machine and of every chain ring hook, shackle, shovel and pulley block used in hoisting or as means of suspension of the safe working load shall be ascertained by adequate means. Every hoisting machine and all gear referred to above shall be plainly marked with the safe working load. In case, a hoisting machine having a variable safe working load, each safe working load and the conditions under which it is applicable shall be clearly indicated. No part of any machine or any gear referred to above in this paragraph shall be loaded beyond its specified capacity. - In case of departmental machines, the safe working load shall be notified by the engineer as regards contractor's machines, the contractor shall notify the safe working load of the machine to the engineer whenever he brings any machinery to site of

Tender Documents for proposed Furnishing & allied works for BO Dhaura Tanda

work and get it verified by the engineer concerned. - Motors, gearing, transmission, electric wiring and other dangerous parts of hoisting appliances should be provided with efficient safeguards, hoisting appliances should be provided with such means as will reduce to the minimum of the risk of any part of a suspended load becoming accidentally displaced. When workers are employed on electrical installations that are already energized, insulating mats, wearing apparel, such as gloves, sleeves and boots as may be necessary should be provided. The workers should not wear any rings, watches and carry keys or other materials that are good conductors of electricity. - These safety provisions should be brought to the notice of all concerned by display on a notice board at a prominent place at work spot. The person responsible for compliance of the safety code shall be named therein by the Contractor. - To ensure effective enforcement of the rules and regulations relating to safety precautions the arrangements made by the Contractor shall be open to inspection by the Labour Officer, Engineers of the Department or their representatives. - Notwithstanding the above clauses there is nothing in these to exempt the Contractor from the operations of any other Act or Rule in Force in the Republic of India.

WORK PERFORMED AT CONTRACTOR'S RISK: The Contractor shall take all precautions necessary and shall be responsible for the safety of the work and shall maintain all safe guards, including providing for guards, proper lights, signs, temporary passages, or other protection necessary for the purpose. All work shall be done at the Contractor's risk, and if any loss or damage shall result from fire or from other cause, the Contractor shall promptly repair or replace such loss or damage free from all expenses to the Bank. The Contractor shall be responsible for any loss or damage to materials, tools or other articles used or held for use in connection with the work. The work shall be carried on and completed without damage to any work or property of the Bank or of others and without interference with the operation of existing machinery or equipment, if any.

CONTRACTOR'S LIABILITY AND INSURANCE From commencement to completion of works, the Contractor shall take full responsibility for the care of the work and for taking precautions to prevent loss or damage to the work to the maximum extent possible and shall be liable for any damage or loss that may arise to the works or any part thereof from any cause whatsoever including causes of fire, lightning, explosion, fire, earthquake, storm, hurricane, floods, inundation, subsidence, landslides, rock slides, riots (excluding civil war, rebellion, revolution and insurrection) or any latent defect or damage and shall at his own cost repair and make good the same so that at all times the work shall be in good order and condition and in conformity in every respect with the requirements of the Contract.

Explanation: For the purpose of this condition, the expression "from commencement to completion of works" shall mean the period starting with the date of issue of the work order or date of handing over of site whichever is later and ending with issue of Virtual Completion Certificate. For the purpose of this Insurance clause only, handing over of site shall also include any handing over of space to the Contractor for the purpose of storage of materials and equipment.

Without limiting the obligations and responsibilities under this condition, the Contractor shall insure and keep insured the works from commencement to completion, as aforesaid, as increased by 25% of the contract value against the risk of loss or damage from any cause whatsoever including the causes enumerated in the foregoing Clause (a). In the event of there being a variation in the nature and extent of the works, the Contractor shall from time to time increase or decrease the value of the insurance correspondingly. All the premia for the insurance shall be borne and paid by the Contractor. The said insurance shall also provide cover for the removal of debris of the lost or damaged works. The said insurance shall be in the joint names of the Bank and the Contractor, Bank's name being mentioned first in the policies and the Contractor shall deposit with the Bank the said policy or Policies before commencing the work. All money payable by the insurer under such Policy/Policies shall be recovered by the Bank only and may be paid to the Contractor or any other agency of Bank's choice in the installments for the purpose of rebuilding or replacing or repairing the works and/or goods destroyed or damaged as the case maybe.

The Contractor shall at all times indemnify and keep indemnified the Bank against all losses, claims, damages or compensation including under the provisions of the payment of the Wages Act 1936, Minimum Wages Act 1948, Bank's Liability Act 1938, Workman's Compensation Act 1923, the Maternity Benefit Act 1961, the Bombay Shops and Establishments Act 1947, Industrial Disputes Act 1947, and Contract Labour (Regulation and Abolition) Act 1970 and Employees State Insurance Act 1948, Motor Vehicles Act 1988 or any modifications thereof or under any other law relating thereto and rules made there under from time to time or as a consequence of any accident or injury to any workman or other person in or about the work whether in the employment of the Bank or Contractor or not, and also

Tender Documents for proposed Furnishing & allied works for BO Dhaura Tanda

against all costs, charges and expenses of any suit, action or proceedings whatsoever out of such accident or injury or combination of any such claims.

Before commencing the work, the Contractor shall without limiting his obligations and responsibilities under this condition, insure against any loss of life or injury to any personnel in the employment of Contractor/sub-Contractor/nominated Sub-Contractor. For this purpose, an insurance shall be taken by the Contractor /Sub- Contractor. Such insurance shall be taken to include both employees/ workmen covered by the Workman's Compensation Act 1923, as well as those employees /workmen not covered by the said Act. Separate insurance policies may be taken for employees/work men covered by Workman's Compensation Act 1923, and employees/ workmen not covered by the said Act. The Contractor shall pay all the premia. Policy/Policies taken under this paragraph for the personnel in employment with the Contractor/Sub-Contractor may be in their Bank's names of the Contractor/Sub-Contractor/nominated Sub-Contractors. In the event of any loss or injury to personnel in employment with the Contractor/Sub-Contractor/nominated Sub- Contractors, the Employee and Contractor shall recover directly from the Insurance Company and ensure that payment of the same is made to the affected parties including the Bank. The policy in original shall be deposited with the Bank. However, if the Policy obtained by the Contractor is not project-specific but covers several works, a certified copy of the Policy shall be submitted to the Bank, together with original which shall be returned after verification.

The Contractor shall at all times indemnify and keep indemnified the Bank against all losses and claims for injuries or damage to any person or any property whatsoever which may arise out of or in consequence of the construction and maintenance of the work and against all claims, demands, proceedings, damages, costs, charges and expenses whatsoever in respect of or in relation thereto. Before commencing the execution of the works, the Contractor shall without in any way limiting his obligations and liabilities under this condition, insure at his cost and expense against any damage or loss or injury which may be caused to any person or property including the Employee or servants of the Bank and the Consultants and their property by or in the course of the execution of the works. Such insurance to be known as the Third Party Insurance shall be in a sum equivalent to two percent of the estimated value of the work, subject to the minimum sum of Rupees One Lacs. The Insurance policy to be so obtained by the Contractor shall be deposited by the Contractor with the Bank within seven days of its issue by the insurer.

The Contractor shall provide the Bank with documentary evidence from time to time, that he has taken all the insurance policies mentioned in the foregoing paragraphs and that he has paid the necessary premia for keeping the policies valid till the works are completed and handed over to Bank.

The Contractor shall ensure that similar insurance policies are taken out by his sub Contractors or nominated Contractors, if any. The Contractor shall be responsible to the Bank or to any other person for any claim or loss resulting from the failure of the Sub-contractors or nominated Sub-Contractors to obtain such insurance policy. While taking the insurance policies, Contractor should indicate clearly to the insurance companies that policies issued should cover their Sub- Contractors and nominated Sub-Contractors also.

If the Contractor and/or his sub-Contractor or nominated Sub Contractor, if any, shall fail to effect and keep in force the insurance referred to above or any other insurance which he/they may be required to effect under the terms of the Contract, then in any such case, the Bank may, without being bound to effect and keep in force any such insurance policy and pay such premium or premia, as may be necessary for that purpose from time to time and deduct the amount so paid by the Bank from any money due or becoming due to the Contractor recover the same as a debt due from the Contractor.

All Insurance Policies shall be obtained from nationalized Insurance Companies only.

Without prejudice to any of its obligations and responsibilities under this condition, the Contractor shall, within 30 days from the date of the Work Order and thereafter at the end of each quarter submit a report to the Bank in Performa 'C' annexed hereto the detailed information on the Insurance Policies as prescribed in the said Performa together with relevant documentary evidence.

No work shall be commenced by the Contractor unless and until he has obtained the insurance or insurance required to be obtained by him under or by the foregoing clauses and no work shall be carried out or continued by the Contractor unless

Tender Documents for proposed Furnishing & allied works for BO Dhaura Tanda

and until such insurance is current and valid at that time. The Contractor, for the payment of the premia shall furnish all the receipts in original along with two photocopies thereof, to the Bank. The original receipts will be returned to the Contractor after verification. The Bank reserves the right for payment for works done subject to fulfillment of this condition and shall instruct the Architect/Consultant accordingly.

In the event of any claim for insurance becoming due on account of any eventuality covered by the respective insurance policy/policies, the Contractor shall reinstate the installation, replace the materials or equipment's or pay compensations to the affected personnel/ Employees or their legal heirs without waiting for settlement of the claim from insurance company.

If the Contractor shall not perform and observe any of the duties and obligations devolving upon him hereunder, and such omission or breach by the Contractor shall involve the Bank in any liability tortuous or otherwise and/or loss or damage, the Bank shall be entitled to the restitution of such loss or damage and shall be entitled to recover the amount of restitution from any moneys due to the Contractor from the Bank under this Contract or any other Contract.

Upon taking possession of the works under the Contract, the Bank shall take out parallel insurance, to insure all persons who are not the Contractor's or the Sub-Contractor's or the nominated Sub- Contractors or the Project Management Consultant's staff or the agent of the Banks authorized representatives on getting the occupation certificate, the Bank will maintain their own insurance Policy and the Contractors will cease to be responsible for the insurance of Bank's personnel.

The Contractor shall ensure the validity of the insurance Policies. The Contractors shall hand over the insurance policies to the Bank through the Architect/Consultant. Once the Architect/Consultant certifies delays, he shall have to ensure that the insurance Policies are progressively extended.

The Banks' insurance Policy shall cover the risk for Banks' agents, Consultants, Architect/Consultants etc. appointed by the Bank.

The Bank shall insure the building in totality on obtaining possession of the building and other structures.

Insurance in respect of damages to persons & property

The contractor shall be responsible for all injury to persons, Neighboring Properties, animals or things, and for all structural and decorative damage to property which may arise from the operation or neglect of himself or of any nominated Sub-contractor's employees, whether such injury damage arise from carelessness, accident or any other cause whatever in any way connected with the carrying out of this contract. This clause shall be held to include inter alia, any damage to buildings, whether immediately adjacent or otherwise, and any damage to Roads, streets, foot- paths, bridges or ways as well as all damage caused to the building and works forming the subject of this contract, by frost or other inclemency or whether. The Contractor shall indemnify the Bank from any such injury or damage to persons or property as aforesaid and also in any award of compensation or damages consequent upon such claims.

The Contractor shall reinstate all damage of every sort mentioned in the Clause, so as to deliver up the whole of the contract works complete and perfect in every respect and so as to make good or otherwise satisfy all claims for damage to the property of third parties.

The Contractor shall indemnify the Bank against all claims, which may be made against the Bank by any member of the public or other third party in respect of anything which may arise in respect of the works or in consequence thereof and shall at his own expense arrange to effect and maintain, Until the virtual completion of the contract, with an approved Office a Policy of Insurance in the joint names of Bank and the Contractor against such risks and deposit such Policy or Policies with the Architect from time to time during the currency of this Contract.

The Contractor shall similarly indemnify the Bank against all claims which may be made upon the Bank whether under The workmen's Compensation Act or any other statute in force during the currency of this Contract or at common law in

Tender Documents for proposed Furnishing & allied works for BO Dhaura Tanda

respect of any employee of the Contractor or any Sub- Contractor and shall at his own expense effect and maintain, until the virtual completion of the contractor, with an approved office, a policy of Insurance in the joint names of the employee and the contractor against such risks and deposits such Policy or Policies with the Architect from time to time during the currency of this Contract.

The Contractor shall be responsible for anything, which may be excluded from the Insurance Policies above referred to, and also for all the damages to any property arising out of and incidental to the negligent or defective carrying out of this contract. He shall also indemnify the Bank in respect of any costs, charges and expenses arising out of any claim or proceedings and also in respect of any award of or compensation of damage arising there from.

The Bank with the concurrence of the Architect shall be at liberty and is hereby empowered to deduct the amount of any damage, compensation, costs, charges and expenses arising or occurring from or in respect of any such claim or damage from any sum or sums due or become due to the contractor.

FIRE INSURANCE: The Contractor shall at the time of signing the Contract, Insure the works and keep them Insured until the virtual completion of the contract, against losses or damages by fire, as approved by the Architect, in the joint names of the Bank and the Contractor (the name of the former being placed first in the policy) for the full amount of the contract and for any further sum being allowed to the Contractor as an authorized extra. Such policy shall cover the property or the Bank only, fees for assessing the claim and in connection with his services generally therein and shall not cover any property of the contractor or of any sub- contractor of the Bank. The contractor shall deposit the policy and receipts for the premiums of the same with the Architect within Ten days of the signing the contract or on receipt of the Work order, whichever is earlier unless otherwise instructed by the Architect. In default of the contractor insuring as provided above, the Bank or the Architect on his behalf may so issue any may deduct the premium paid for any money due to the contractor. The contractor shall as soon as the claim under the policy is settled, or the work reinstated by the insurance office, should they elect to do so, proceed with all due diligence with the completion or the work in the same manner as though the fire had not occurred and in all respects under the same conditions of the contract. The contractor shall be entitled to such extension of the time for completion as the Architect deems fit.

The amount so due as aforesaid shall be total value of the works duly executed and of the contract materials and goods delivered upon the site for use in the work up to and including a date not more than seven days prior to the date of the said certificate less the amount to be retained by the Bank (As hereinafter provided) and loss any installment, previously paid under this clause. Provided that such certificates shall only include the value of the said materials and goods as and from time they are reasonably, properly and not prematurely brought upon the site and then only if properly stored and/or protected weather.)

पी.एस.बी

DAMAGES FOR NON-COMPLETION: If the Contractor fails to complete any or all the works by the date/s named in the relevant clauses for "Date of Completion" and "Extension of Time" and if the Architect/Consultant shall certify in writing on or before the date of issue of the Certificate for the last payment to which the Contractor may become entitled hereunder that the works could reasonably have been completed by the date or within the said extended time, then the Contractor shall pay or allow the Bank the sum to be worked out at Rs. 500/- per Day or 10% of Contract value per day to be recovered as Liquidated Damages (and not by way of penalty) for the delay, beyond the said date or extended time, as the case may be, during which the works shall remain unfinished and such damages may be deducted from any moneys due or which may become due to the Contractor. The maximum amount of Liquidated Damages shall be the amount not exceeding. The contractor shall be bound to extend validity of Insurance Cover till such period of completion as to be considered necessary at their cost.

FAILURE BY CONTRACTOR TO COMPLY WITH CONSULTANT'S INSTRUCTIONS:

If the Contractor after receipt of written notice from the Architect/Consultant in prior consultation with the Bank requiring compliance with such further drawings and/or instructions to remove, fails within seven days to comply with the same, the Architect/Consultant with prior consent of the Bank may employ other persons to execute any such work whatsoever as may be necessary to give effect thereto and all costs incurred in connection therewith shall be recoverable

Tender Documents for proposed Furnishing & allied works for BO Dhaura Tanda

from the Contractor by the Bank on a certificate by the Architect/Consultant as a debt to be deducted by him from any moneys due or to become due to the Contractor.

TERMINATION OF CONTRACT: If the Contractor except on account of any legal restraint upon the Bank preventing the continuance of the works, on account of any of the causes mentioned in Clause “Delay and Extension of time” in the case of a certificate being withheld or not paid when due, shall suspend the works, or, in the opinion of the Architect/Consultant, shall neglect or fail to proceed with due diligence in the performance of his part of the Contract or if he shall more than once make default in the respects mentioned in Clause “Removal of improper work and materials”, the Bank through the Architect/Consultant shall have power to give notice in writing to the Contractor requiring that the works be proceeded with a reasonable manner and with reasonable dispatch. Such notice shall not be unreasonably given and must signify that it purports to be a notice under the provisions of this clause and must signify the act or defaults on the part of the Contractor upon which it is based. After such notice shall have been given, the Contractor shall not be at liberty to remove from the site of work, or from any ground contiguous thereto, any plant or materials belonging to him which shall have been placed thereon for the purpose of the works, and the Bank shall have lien upon such plant and materials to subsist from the date of such notice being given until the notice shall have been complied with. If the Contractor shall fail, for seven days after such notice has been given to proceed with the works as therein prescribed, the Bank may enter upon & take possession of the works and of all such plant and materials thereon intended to be used for the work, and the Bank shall retain and hold alien upon all such plant and materials until the works shall have been completed under powers hereinafter conferred upon him. If the Bank shall exercise the above power, he may engage any other person to complete the works and exclude the Contractor, his agents and servants, from entry upon or access to the same, except that the Contractor or any person appointed in writing may have access at all reasonable times during the progress of the works to inspect, survey and measure the works. Such written appointment or a copy thereof shall be delivered to the Architect/Consultant before the person so appointed comes on to the works, and the Bank shall take such steps as in the opinion of the Architect/Consultant may be reasonably necessary for completion of the works, without undue delay or expenses, using for that purpose the plant and materials above mentioned in so far as they are suitable and adaptable to such use. Upon the completion of the work the Architect/Consultant shall certify the amount of the expenses properly incurred consequent on and incidental to the default of the Contractor as aforesaid and in completing the works by other persons. Should the amount so certified as the expenses properly incurred be less than the amount which would have been due to the Contractor upon the completion of the works by him, the difference shall be paid to the Contractor by the Bank, should the amount of the former exceed the latter, the difference shall be paid by the Contractor to the Bank. The Bank shall not be liable to make any further payment or Compensation to the Contractor for or on account of the proper use of the plant for the completion of the works under the provision herein before mentioned other than such payment as included in the Contract. After the works shall have been so completed by persons other than Contractor, under provision herein before contained, the Architect/Consultant shall give notice to the Contractor, to remove his plant and all surplus materials as may not have been used in the completion of the works, from the site. If such plant and materials are not removed within a period of 14 days, after the notice shall have been given, the Bank may remove and sell the same, holding the proceeds, less the cost of the removal and sale, to the credit of the Contractor. The Bank shall not be so responsible for any loss sustained by the Contractor from the sale of the plant in the event of the Contractor not removing it after notice.

NOTICES: Notices of the Bank to the Architect/Consultant or the Contractor may be served personally or by being left at or sent by registered post to the last known place of abode or business of the party to whom the same is given or in the case of the Contractor by being left on the works. In the case of company or Corporation, notices may be served at or sent by registered post to the registered office of the Company or Corporation. Any notice sent by registered post shall be deemed to be served at the time when, in the ordinary course of post, it would be delivered.

TERMINATION OF CONTRACT BY THE BANK If the Contractor being an individual or a firm, commits any act of insolvency or shall be adjudged as Insolvent or being an incorporated Company shall have an order for Compulsory winding up or applies for voluntary winding up or subject to the supervision of the Court and of the Official Assignee or the Liquidator in such acts of Insolvency or winding up shall be unable within seven days after notice to him requiring

Tender Documents for proposed Furnishing & allied works for BO Dhaura Tanda

him to do so, to show to the reasonable satisfaction of the Architect/Consultant that he is able to carry out and fulfill the Contract, and to give security therefore, if so required by the Architect/Consultant or if the Contractor (whether an individual firm or incorporated Company) shall suffer execution to be issued, or shall suffer any payment under this Contract, to be attached by or on behalf of any of the creditors of the Contractor. Or shall assign or sub-let the Contract without the consent in writing of the Architect/Consultant first obtained.

Or shall charge or encumber this Contract or any payments due or which might become due to the Contractor there under,

Or if the Architect/Consultant shall certify in writing to the Bank that the Contractor has abandoned the Contractor

Or Has failed to commence the works, or has without any lawful excuse under these conditions suspended the progress of the works for seven days after receiving from the Consultant written notice to proceed, or

Or Has failed to proceed with the works with such due diligence and failed to make such due progress as would enable the works to be completed within the time agreed upon, or

Or Has failed to remove materials from the site or to pull down and replace work for seven days after receiving from the Consultant written notice that the said materials or work were condemned and rejected by the Architect/Consultant under these conditions, or

Or Has neglected or failed persistently to observe and perform all or any of the acts, matters or things by this Contract to be observed and performed by the Contractor for seven days after written notice shall have been given to the Contractor requiring the Contractor to observe or perform the same, or

Or Has to the detriment of good workmanship or in defiance of the Architect/Consultant instructions to the contrary sublet any part of the contract

Then in any of the said cases the Bank may not withstanding any previous waiver, after giving seven days notice in writing to the Contractor, determine the Contract but without thereby affecting the powers of the Architect/Consultant or the obligations and liabilities of the Contractor, the whole of which shall continue in force as fully as if Contract has not been determined and as if the works subsequently executed had been executed by or on behalf of the Contractor. And further, the Bank, may enter upon and take possession of the work and all plant, tools, scaffoldings, sheds, machinery, steam and other power, utensils and materials lying upon the premises or the adjoining lands or Roads and use the same as his own property or may employ the same by means of his own servants and workmen carrying on and completing the works or by employing any other Contractors or other persons to complete the works, and the Contractor shall not in any way interrupt or do any act, matter or things to prevent or hinder such other Contractor or other person or persons employed for completing and finishing or using the materials and plant for the works. When the works shall be completed or as soon thereafter as convenient, the Architect/Consultant shall give a notice in writing to the Contractor to remove his surplus materials and plant, and should the Contractor fail to do so within a period of 14 days after receipt thereof by him the Bank shall sell the same by public auction, or otherwise and shall give credit to the Contractor for the amount realized after deducting there from the costs of removal and sales by the Bank for the values of the said plant and material so taken possession of by the Bank and the expense or loss which the Bank shall have been put to in procuring the works to be completed and the amount, if any, owing to the Contractor and the amount which shall be so certified shall thereupon be paid by the Bank, to the Contractor, or, by the Contractor to the Bank, as the case may be, and the certificate of the Architect/Consultant shall be final and conclusive between the parties. On termination of the Contract, the Contractor shall forthwith remove himself and his workmen from the works site.

TERMINATION OF THE CONTRACT BY THE CONTRACTOR:

If payment of the amount payable by the Bank under the Certificates of the Architect/Consultant with interest as instructions, he shall proceed with the work conforming to the provision or Regulations or Bye laws in question.

Tender Documents for proposed Furnishing & allied works for BO Dhaura Tanda

provided for hereinafter shall be in arrears and unpaid for thirty days after notice in writing requiring payment of the amount with interest as aforesaid shall have been given by the Contractor to the Bank (or if the Bank interferes with or obstruct issue of any such Certificates), or the Bank commits any 'Act of Insolvency', or if the Bank being an individual, or firm shall be adjudged insolvent or (being an incorporated company) shall have an order made against it or pass an effective resolution for winding up either compulsorily or subject to the supervision of the court or Voluntarily, or if the official Assignee of the Bank being an individual, or firm shall be adjudged insolvent or (being an incorporated company) shall have an order made against it or pass an effective resolution for winding up either compulsorily or subject to the supervision of the court or Voluntarily, or if the official Assignee of the Bank shall repudiate the Contract, or if the Official Assignee or the Liquidator in any such winding up fails within fifteen days after notice to him requiring him to do so, to show to the reasonable satisfaction of the Contractor that he is able to carry out and fulfill the Contract and to make all payments due, and to become due hereunder and if required by the Contractor, to give security for the same, or if the works be stopped for three month sunder an order of the Architect/ Consultant or the Bank or by any injunction or other orders of any court of law, then and in any of the said cases the Contractor shall be at liberty to determine the Contract by notice in writing to the Bank, through the Architect/Consultant, and he shall be entitled to recover from the Bank payment for all works executed and for any loss he may sustain upon any plant or material supplied or purchased or prepared for the purpose of the Contract.

In arriving at the amount of such payment, the net rates contained in the Contractor's original tender shall be followed, or where the same may not apply, valuation shall be made in accordance with "Prices for Extras, etc. Ascertainment thereof" FORE CLOSURE OF CONTRACT IN FULL OR IN PART.

If at any time after acceptance of the tender the Bank / Architect / Consultant shall decide to abandon or reduce the scope of the works for any reasons whatsoever and hence not require the whole or any part of the works to be carried out he shall inform the Contractor in writing to that effect and the Contractor shall have no claim to any payment or compensation or otherwise whatsoever, on account of any profit or advantage which he might have derived from the execution of the works in full but which he did not derive in consequence of the foreclosure of the whole or part of the works.

The Contractor shall be paid at the Contract rates full amount for woks executed at site, and in addition, reasonable amount as Certified by the Architect/Consultant for the value of such material (which material shall thereupon become the property of the Bank) and also such further allowances as the Architect/Consultant may think reason able and fair in respect of (a) Any expenditure incurred by the Contractor towards preliminary works etc. and (b) Other reasonable and proper engagement the Contractor may have entered into for carrying out the work.

COMPLIANCE TO BANK'S/LEGAL NORMS NOTICES

- a) The Contractor shall give all notices and pay all fees and shall comply with all Acts and Regulations for the successful completion of the Contract works.
- b) **AUTHORITIES, NOTICES, PATENTS, RIGHTS & ROYALTIES:** The Contractor shall conform to the provisions of all the statutes relating to the works, and to the Regulations and bye laws of any local Authority, and of any Water, Lighting, Electric supply, and of other Companies or Authorities with whose systems the structure is proposed to be connected, and shall before making any variation from the drawings or specifications that may be necessitated by so confirming, give to the Architect/Consultant written notice, specifying the variations proposed to be made and the reason for making it, and apply for instruction thereon. In case the Contractor shall not within 10 days receive such
- c) The Contractor shall bring to the attention of the Architect/Consultant all notices required by the said Acts, Regulations or Bye-laws to be given to any Authority by the Bank or the Architect/Consultant and pay to such Authority, or to any public Officer, all fees that may be properly chargeable in respect of the works, and lodge the receipts with the Architect/Consultant.

Tender Documents for proposed Furnishing & allied works for BO Dhaura Tanda

d) The Contractor shall indemnify the Bank against all claims in respect of patent rights, design, trademarks of name or other protected rights in respect of any constructional site, machine work or material used for or in connection with the works or temporary works and against all claims, demands, proceedings, damages, costs, charges and expenses whatsoever in respect thereof or in relation thereto. The Contractor shall defend all actions arising from such claims, unless he has informed the Architect/Consultant before any such infringement and received their permission to proceed, and shall himself pay all royalties, license fees, damages, costs and charges of all and every sort that may be legally incurred in respect thereof. All statutory fees, deposits etc paid by the contractor for permanent works to be handed over to Bank which shall be reimbursed to him by the Bank against documentary proof.

e) The Contractor shall assist and co-ordinate with the Architect/Consultant in obtaining all statutory approvals and/or amendments to such approvals as per the rules in force from Municipality and other local bodies. Any expenditure incurred in obtaining such approvals is deemed included in the rates quoted by the Contractor.

Notices to Local Bodies: The Contractor shall comply with and give all notices required under any law, rule, regulations, or bye-law of parliament, State Legislature or Local Authority relating to works. The Contractor shall before commencing the execution of work issue a certificate to the Bank/ Architect/Consultant that he has obtained all the permissions Registrations and give all the notices as are required to be obtained or given under law particularly blasting permission the Police permission etc.

MUNICIPAL REGULATIONS: The whole of the work is to comply with the requirements and byelaws of the concerned Municipal Corporation and local bodies.

WAGES OF LABOUR EMPLOYED BY THE CONTRACTOR:

a) The Contractor shall pay all labour employed by him at rates fixed by him at the commencement of the Contract as per the Labour Laws. Wages as applicable for the construction work as per norms stipulated by the Bareilly Development Authority or the contractor shall follow any other statutory body or authority of the State of Uttarpradesh or Government of India. No violation of such statutory laws and rules shall be permissible. This will also include the minimum and the maximum allowable wages for various categories of labour to be employed by the contractor.

b) All wages shall be paid in full and without any deduction whatsoever at the approved rates and for full time actually worked during the wage period. Officers of Architect/Consultant or an Officer of the Bank as may be authorized in that behalf shall have power to exercise supervision over the labour employed by the Contractor, and for such other purpose any of these officers may inspect the wage books, muster books and other labour records of the Contractor. In the event of the report of such Officer/s showing that the proper rates of wages are not being paid, or that in any manner whatsoever the dealings between the Contractor and his Labours are not satisfactory, the Architect/Consultant/Bank shall pass such orders upon the report as he considers desirable, and those orders shall be final and binding upon the Contractor. The contractor shall indemnify and keep indemnified the Architect/Consultant and / or the Bank against any claim arising from failure of the Contractor to comply with such labour laws.

c) The contractor shall register with Assistant Labour Commissioner (Central) as contractor approved by the Bank.

DISPLAY OF NOTICES The Contractor shall display all permissions licenses registration certificates and other statements required to be displayed under various labour laws and other legislation's applicable to the works at the site office and also maintain the requisite register/records factually and up to date and keep them ready for inspection by the concerned authorities and also make available the same to the Architect/Consultant / Bank for inspection.

INSURANCE POLICIES: i) The Contractor shall not commence any work at site, until all the insurance Policies, as required here and in terms of the General Conditions of Contract, have been submitted to the Bank. Renewal of the same if required due to extension of time for completion or similar reasons is also the responsibility of the Contractor.

Tender Documents for proposed Furnishing & allied works for BO Dhaura Tanda

ii) Notwithstanding anything to the contrary mentioned in the Contract, Contractors have to submit all Insurance Policies to the Bank directly to make the Bank satisfy themselves regarding adequacy of values of insurance, validity etc. as per contractual clauses.

iii) The Contractor shall arrange for renewals of these policies on their own. Any omissions to do so or delay in non-receipt of any information will be no excuse for failure to renew them or keep them in force without a break.

INDEBTEDNESS AND LIENS:

a) The Contractor agrees to furnish the Bank from time to time during the progress of the work as requested, verified statements showing the Contractors' total outstanding indebtedness in connection with the work covered by the Contract.

b) Before final payment is made, the Bank may require the Contractor to furnish the Bank with satisfactory proof that there are no outstanding debts or liens in connection with the Contract. If during the progress of the work, the Contractor shall allow any indebtedness to accrue to Sub-Contractors or others and shall fail to pay or discharge same within Seven days after demand, then the Bank may withhold any money due to the Contractor until such indebtedness is paid, or apply the same towards the discharge there- of.

INDIAN STANDARD CODE: The relevant I.S. Code of practice shall be the latest version with its amendments/revisions. The Contractor shall keep and maintain copies of the latest editions of relevant I.S. Codes at the work site and make it available to Architect/Consultant when required.

TREASURE TROVE: Should any important and valuable materials/items be found while carrying out the works, the same shall be the property of the Bank. The Contractor shall give immediate notice to the Architect/Consultant of any such discovery and shall hand over any such treasure to the Bank on demand.

TECHNICAL AUDIT

a) The work is liable to be technically audited by the Chief Technical Examiner of the Central Vigilance Commission Government of India from time to time. The Contractor at his own cost should carry out any defects, improvements or testing etc. pointed out by the Architect/Consultant/Bank and any deduction suggested by the Architect/Consultant/Bank will be effected.

b) The Bank shall have a right to cause a technical examination and audit of works and final bills of the contractor including all supporting vouchers, abstract, etc. to be made at the time of payment of the bill. If as a result of this examination or otherwise any sum is found to have been overpaid in respect of any work done by the contractor under the contract the contractor shall be liable to return the amount of over payment and it will be lawful for the Bank to recover the same from any sum or sums due to him and in any other manner legally permissible and if it is found that the Contractor was paid less than what was due to him under the contract in respect of any work, executed by him under the contract, the amount of such under payment shall be duly paid by the Bank.

c) Any sum of money due and payable to the contractor (including security deposit returnable to him) under this contract may be appropriated by the Bank and set off against any claim of the Bank for the payment of a sum of money arising out of or under any other contract made by the Contractor with the Bank.

ROLE OF THE ARCHITECT/CONSULTANT: Architect/Consultant's duties are to design, control and supervise the works and to test any materials to be used or workmanship employed in connection with the works, quality control, project scheduling and monitoring and co- coordinating with all other agencies and Civil Contractor, checking of measurements, certification of bills, preparing extra deviation items, preparing minutes of meetings etc.

Wherever, it is mandatory by law that the Architect/Consultant so appointed by the Bank shall be registered with the council of architecture/Competent Authority.

The Contractor shall afford the Architect/Consultant every facility and assistance for examining the works and materials and checking and measuring time and materials. The Architect/Consultant shall have no power to revoke, alter, enlarge,

Tender Documents for proposed Furnishing & allied works for BO Dhaura Tanda

or relax any requirements of this Contract, or to sanction any day-work, additions, alterations, deviations or omissions unless such an authority may be specially confirmed by a written order of the Bank.

The Architect/Consultant shall act in consultation with the Bank regarding quality of works, interpretation of drawings, contract documents and finalize the selection of finishing materials. The Architect/Consultant shall check/ record the measurements made by Contractor's representative for all items of works and on completion hand over the records to the Bank.

The Architect/Consultant shall have the power to give notice to the Contractor or his Engineer In charge about the non-approval of any work or materials and such works shall be suspended or the use of such materials should be discontinued until the decision of the Architect/Consultant in consultation with Bank if required is obtained. The work will from time to time be visited by the Architect/Consultant / Bank but such examination shall not in any way exonerate the Contractor from the obligation to remedy any defects which may be found to exist at any stage of the work or after the same is completed. Subject to the limitations of this clause, the Contractor shall take instructions only from the Architect/Consultant as the case may be. In other words the contractors shall take total responsibility for the execution of work / items of work by using quality materials and providing best of workmanship to fulfill the true intent of the tender provision.

The Architect/Consultant shall have such other powers and discharge other functions as are specifically provided in this contract including such incidental or consequential powers or duties, subject always to such specific instructions or directions of the Bank, which shall be duly notified to the Contractor.

TO DEFINE TERMS AND EXPLAIN PLANS: The various parts of the Contract are intended to be complementary to one another; but should any discrepancy appear, or any misunderstanding arise as to the import of anything contained therein, the explanations of the Architect/Consultant shall be final and binding. The correction of any errors or omissions of the Drawings and Specifications may be made by the Architect/Consultant, when such correction is necessary to bring out clearly the intention, which is indicated by a reasonable interpretation of the drawings & Specifications as a whole.

MATTERS TO BE FINALLY DETERMINED BY THE ARCHITECT/CONSULTANT:

The Architect/Consultant's decision, opinion, direction, Certificates (except for payments) with respect to all or any of the matter and the schedule of rates, hereof shall be final and conclusive and binding on the parties hereto and shall be without appeal. Banks' instructions if any, in this regard in case of any urgency, shall also be confirmed/vetted by the Architect/Consultant at the earliest possible.

Any of the decision, opinion, direction certificate, or valuation of the Architect or any refusal of the Architect to give any of the same shall be subject to the right of Arbitration and review in the same way in all respect (including the provision as to opening the reference) as if it were a decision of the Architect under the following clause.

TYPOGRAPHICAL OR CLERICAL ERRORS: The Architect/Consultant's clarifications regarding partially omitted particulars or typographical or clerical errors shall be final and binding on the Contractor.

SITE VISITS: The Architect/Consultant /Bank shall visit the site from time to time at their discretion, or when expressly called upon to do so, to co-ordinate various activities and/or to answer such queries that may be posed at site on Air-Conditioning system drawings.

ADDRESS FOR SERVICE: All letters and Notices under or pursuant to these presents shall be hand delivered against acknowledgment or sent by Registered Post with Acknowledgment Due at the respective addresses mentioned below. The concerned Party to all others shall duly intimate any change in the addresses.

Tender Documents for proposed Furnishing & allied works for BO Dhaura Tanda

Address for the Bank

THE ZONALMANAGER, PUNJAB AND SIND BANK, 148 CIVIL LINES, GAGANDEEP COMPLEX, BAREILLY, UTTAR PRADESH – 243001, E MAIL : ZO.BAREILLY@PSB.CO.IN

Address of the Architect/Consultants

M/s Yogendra Architects, C/O Mr. Y. M. Sexena, Kamal Talkies Building, Bareilly-243001

DISPUTES

SETTLEMENT OF DISPUTE BY ARBITRATION

Disputes and differences of any kind whatsoever arising out of or in connection with this contract or the carrying out of the works (whether during the progress of the works or within one year after their completion, or within one year after the determination or abandonment or breach of the contract) excepting however, on matters referred to in clause 9.3 and 9.5 of General Conditions of Contract hereof, shall be referred by either party for arbitration after giving at least 30 days notice in writing to the other(s) (hereinafter referred to as the 'Notice for Arbitration') clearly setting out the items of disputes for reference to a Sole Arbitrator to be appointed as here in after provided.

For the purpose of appointing the Sole Arbitrator referred to above, the Bank will send to the Contractor within thirty days of the Notice for Arbitration, a panel of three names of persons who shall be presently unconnected with the organization of the Bank and the Contractor.

The Contractor shall on receipt of the names as aforesaid, select any one of the persons so named to be appointed as a Sole Arbitrator and communicate his name to the Bank within thirty days of receipt of the names. The Bank shall thereupon without any delay appoint the said person as the Sole Arbitrator. If the Contractor fails to communicate such selection as provided above within the period specified, the Bank shall make the selection and appoint selected person as the Sole Arbitrator. In the event, the contractor communicates disagreement to appointment of Sole Arbitrator as selected by the Bank than notwithstanding such disagreement, the person selected, as sole Arbitrator by the Bank shall be the sole Arbitrator.

If the Bank fails to send to the Contractor the panel or three names as aforesaid within the period specified, the Contractor shall send to the Bank a panel of three names of persons who shall all be un connected with either party. The Bank shall on receipt to the names as aforesaid select any one of the person's names and appoint him as the Sole Arbitrator. If the Bank fails to select the person and communicate such selection to the Contractor, the Contractor shall be entitled to appoint one of the persons from the panel as the Sole Arbitrator and communicate his name to the Bank, provided however in case if delay by the contractor as regards such selection, the Arbitrator selected by the Bank shall be appointed as sole Arbitrator.

If the Arbitrator so appointed is unable or unwilling to act or resigns his appointment or vacates his office due to any reason whatsoever, another Sole Arbitrator shall be appointed as aforesaid.

The decision of the Architect/Consultant with respect to the matters referred in clause 9.3 and 9.5 of General condition of Contract herein, shall be final and outside the scope of arbitration. The Sole Arbitrator shall have power to open up, review and revise any certificate, opinion or decision, requisition or notice save in regard to matters enumerated in clause 9.3 and 9.5 of General Conditions hereof written and to determine all other matters in dispute which shall be submitted to arbitration and of which notice shall have been given as aforesaid. Subject to aforesaid, the Arbitration shall be governed by the Arbitration Act, and Conciliation 1946 or any other statutory modification thereof. The Award of the Arbitrator shall be final and binding on the parties. It is hereby agreed that in all disputes referred to Arbitration, the Arbitrator shall give a separate Award in respect of each dispute or difference in accordance with the terms of the contract and give a reasoned Award.

Tender Documents for proposed Furnishing & allied works for BO Dhaura Tanda

The fees, if any, of the Arbitrator shall, if required to be paid before the award is made and published, be paid half and half by each of the parties. The cost of the reference and of the award including the fees, if any, of the Arbitrator, shall be directed to be borne and paid by such party or parties to the dispute, in such manner or proportion as may be directed by the Arbitrator in the Award.

The Bank and the Contractor hereby also agree that the Arbitrator under this clause shall be a condition precedent to any right to action under the contract with regard to the matters hereby expressly agreed to be so referred to arbitration. Settlement of dispute by arbitration: All disputes and differences of any kind whatsoever arising out of or in connection with the contract or the carrying out of the works (whether during the progress of the works or within one year after their completion, or within one year after the determination or abandonment or breach of the contract) shall be referred to and settled by the Architect, who shall state his decision in writing. Such decision in writing may be in form of a final certificate or otherwise. The decision of the Architect with respect of any of the expected matters shall be final and without appeal as stated in the relevant clause on “matters to be finally decided by the Architect.”(Clause no. 11.3).

But if either the Bank or the contractor be dissatisfied with the decision of the Architect on any matter, question or dispute of any kind (except any of the expected matters) or as to the withholding by the Architect of any certificate to which the contractor may claim to be entitled, then and in any such case either party (the Bank or the Contractor) may within (28 days) after receiving notice of such decision, give a written notice to the other party through the Architect requiring that such matters in dispute be arbitrated upon. Such written notice (hereinafter referred to as the ‘notice for arbitration’ shall clearly set out the items of disputes for reference to a Sole Arbitrator to be appointed as herein after provided: specify the matters which are in dispute and such dispute and difference of which such written notice has been given and no other shall be and is hereby referred to the Arbitrator being a fellow of the Indian Institute of Architects to be agreed upon and appointed by both the parties or in case of disagreement as to the appointment of a single Arbitrator, to the arbitration of two Arbitrators both being fellows of the Indian Institute of Architects, and to be appointed by each party, which Arbitrators shall before taking upon themselves the burden of re-reference appoint an umpire. The Arbitrator, the Arbitrators or the Umpire shall have the power to open up, review and revise any certificate, opinion, decision, requisition or notice save regard to the expected matters referred to the preceding clause, and to determine all matters in dispute which shall be submitted to him or them and of which notice shall have been given aforesaid. Upon every or any such reference the cost of an incidental to the reference and award respectively shall in the direction of the Arbitrator, or Arbitrators or the Umpire who may determine the amount thereof, or direct the same to taxed as between attorneys and client or to between party and party, and shall direct by whom and to whom and in what manner the same shall be borne and paid. This submission shall be deemed to be a submission to The Arbitration act, 1989 or any statutory modification thereof. The award of the Arbitrator, or the Arbitrators, or the Umpire shall be final and binding on the parties, Such reference except as to the withholding by the Architect of any Certificates under clause 7.3.5 to which the Contractor claims to be entitled, shall not be opened or entered upon until after the completion of alleged completion of the works or until after the practical cessation of the works arising from any cause unless with the written consent of the Bank and Contractor.

ARBITRATION: Any dispute, controversy or claims out of or relating to this Work Order or breach, or termination or invalidity thereof, shall be settled by Arbitration in accordance with the Arbitration and Conciliation Act, 1996 as at present in force.

LEGAL: All disputes and differences of any kind whatsoever arising out of or in connection with the Work Order whether during or after completion of contract shall be deemed to have arisen at Bareilly and only Courts in Bareilly shall have jurisdiction to determine the same.

WORK TO BE CONTINUED DURING THE PENDANCY OF THE ARBITRATION

The Contractor shall continue with the construction works with due diligence and speed so as to complete the same within the period agreed upon, notwithstanding any dispute or difference or question is referred to arbitration. The works shall not be delayed on account of any such reference made to the Arbitrators.

Tender Documents for proposed Furnishing & allied works for BO Dhaura Tanda

SPECIAL CONDITIONS OF CONTRACT

- Tenderer shall go through all documents before quoting rates and provide for necessary cost as may be included in either bill or material or specifications.
- Tenderer shall be given prices in blank column Entries in English made in ink. Arrive also at the grand total must also fill in all "rates only columns" and sign all corrections.
- Tenderer shall be invalid unless all rates are filled in. No arbitrary condition shall be submitted. All the legal partners of the firm shall sign tenders.
- The Tenderer shall sign each of the tender documents.
- The Tenderer whose tender is accepted shall be bound to enter in to the contract within 15 days of intimation from BANK.
- Work shall be done night and day without extra charge, if necessary.
- Tenderer shall provide for stacking of materials in such a way as to facilitate rapid checking of quantities.
- Materials supplied by bank shall be used only in bank's work.
- Contractors shall pay any local charges relating to execution of work.
- Contractor shall allow for all wastages in the rates.
- Contractor shall arrange for all temporary connections.
- No extras shall be paid, quantity sheets and drawings both are to be considered jointly and Architect/Consultant is the final authority for the interpretation.
- Site instruction shall be deemed for proper execution, and shall be carried out without extra charge.
- Order book with numbered pages shall be kept on site. Contractor shall carry out all instructions properly.
- Contractors shall insure whole work against fire, PICT and third party

SPECIFICATIONS GENERAL

These specifications are for work to be done, items to be supplied and materials to be used in the works as shown and defined on the drawings and described herein all under supervision and to the entire satisfaction of the Architect/Consultant & bank.

The workmanship is to be the best available and of a very high standard, use must be made of specialist tradesmen in all types of work and necessary allowance must be made for the same in the rates quoted.

The materials and items to be provided by the contractor shall be the best of their respective kinds as specified in the tender and in accordance with the samples approved, where materials or products are specified in these specifications and/or Bill of Quantities by the name of the manufacturer of the brand name, trade name or catalogue reference, the contractor will require to obtain prior approval of the Architect/Consultant and bank for using substitute material or product. The contractor shall produce all invoices, vouchers or receipted accounts for any materials if called upon to do so by the Architect/Consultant and bank.

Samples of all materials are to be submitted to the Architect/Consultant/bank for his approval before the contractor orders or delivers in bulk in the site. Samples together with their packing are to be provided by the Contractor free of charge and the bank and designer for comparison with the materials that will be delivered to the site will retain approved samples.

Should the Architect/Consultant/bank reject any materials, they will be removed from the site at the Contractor's expense. Also the contractor will be required to submit specimen finishes of colors, fabrics, etc. for approval of Architect/Consultants/ bank before proceeding with the works. Should it be necessary to prepare shop drawings, and then four copies of such drawings shall be submitted for approval of the Architect/Consultant who will retain two copies, all at the Contractor's expenses.

Tender Documents for proposed Furnishing & allied works for BO Dhaura Tanda

SPECIFICATION OF MATERIALS WHICH ARE NOT SPECIFIED IN SCHEDULE OF QUANTITIES

All the material to be used shall be from the list of ISI approved Brand. Any deviation from this shall be got approved from Architect/Bank, the contractor shall submit samples of materials used for verification's and produce Bill in original.

SAMPLES	After receipt of the bids but prior to award of the contract, bidder shall, upon notification from bank submit samples of materials he intends to use. The bank shall reserve the right to evaluate the sample with regard to the specification before award of work. Samples as directed by the Architect/Bank for various items shall be prepared/brought for approval without any cost.
PLYWOOD	Plywood should be Termite and Powder proof.
GLASS	Glass shall be float glass of Modiguard company
TIMBER	Wherever specified shall be teak wood from Central Province (C.P.)/Ghana best quality. It shall be well seasoned, uniform in colour, free from sap wood, wares, free from large and loose knots, cracks, shakes and other defects. All wood shall be treated for anti termite treatment with two coats of solignum paint and two coats of fire retardant paint.
HARDWARE	Hinges, Handles, Stoppers, Stays etc. wherever required shall be brass/stainless steel of approved shape and size only.
UPHOLESTRY	Fabric or upholstery material wherever called for shall be of the colour, texture and manufacture approved by the Architect/Bank
WORKMANSHIP	The work involved calls for high standard of workmanship and shall be carried out and completed in the best possible manner keeping modern trend of artistic finishes and designs in view so as to make the entire work/furnishing aesthetic looking, keeping in harmony with other furnishing in the area.

DIMENSIONS & JOINTS

The dimensions mentioned in the schedule of quantities and drawings are approximate. The contractor may suggest small deviations in the dimensions so as to make the individual items as also the entire job functionally sturdy, comfortable as well as aesthetic in look. The final decisions regarding sizes of various members and working dimensions etc. will however be taken at the time of approval of sample. The contractor should take actual dimensions available at site before fabrication. The joints shall be perfect and sturdy and shall preferably be machine made and assembled with approved quality synthetic glue.

The structural design of different members and also the items as a whole shall be sturdy and capable of withstanding the various loads likely to be subjected to in day to day use.

ADDITIONAL MEMBERS AND FIXTURES: The contractor shall provide additional members wherever necessary for providing door, openings, cut-outs, etc. to facilitate fixing of light fixtures, plug points, air-conditioning supply and return grilles etc. The work includes cost of fittings and fixtures & fixing the various items in position in floors, walls, ceilings etc. in the building in accordance with two drawings of as directed by the Architect/Bank. It will be also necessary to make holes, chases, etc. in floors, walls, ceilings, R.C.C. etc. as may be required for fixing the partition. The contractor shall allow for such provisions in his quoted rate. It will be deemed that while quoting rates the contractor has taken into account all foreseeable contingencies which will include making good disturbed floors, walls, ceilings, etc. to their original condition.

Tender Documents for proposed Furnishing & allied works for BO Dhaura Tanda

SCHEDULE OF APPROVED MAKES FOR MATERIALS IN CIVIL, FURNISHING & FINISHES WORKS WHICH ARE NOT SPECIFIED IN SCHEDULE OF QUANTITIES

In case it is established that the brands specified below are not available in the market are subject to the approval of the alternative brand by the Architect

S. NO.	ITEM	COMPANY MAKE
1	REINFORCEMENT STEEL	TATA, SAIL, JINDAL, RATHI KAMDHENU
2	AAC BLOCK	BILT, MAGNA, ULTATECH OR LOCAL AVAILABLE
3	CEMENT	ORDINARY PORTLAND CEMENT 43 GRADE MANUFACTURED BY ACC/BINANI/JAYPEE/ ULTRA TECH/AMBUJA
4	POLYSULPHIDE SEALANT	PIDISEAL BY M/S PIDILITE INDUSTRIES LTD., FOSROC, SHALIMAR, ROFF
5	WATER PROOFING COMPOUND	CICO , FOSROC, DR FIXIT, ROFF
6	SHUTTERING PLYWOOD	GREEN, CENTURY, ARCHID
7	TOUGHENED GLASS	TRUTUFF OR EQUIVALENT
8	GLASS/LACQUERED GLASS	MODI FLOAT. ST. GOBAIN., ASAHI
9	WIRED GLASS	6MM THK. WIRED GLASS MANUFACTURED BY HINDUSTAN SAFETY GLASS WORKS LTD. CALCUTTA, OR VALLABH GLASS WORKS GUJRAT./HARYANA SHEET GLASS.
10	WHITE CEMENT	J.K. WHITE CEMENT , BIRLA WHITE CEMENT
11	DISTEMPER, PAINT	ENAMEL, PLASTIC EMULSION MANUFACTURED BY BERGER PAINTS, ASIAN PAINTS, NEROLAC , SHALIMAR PAINT, ICI.
12	PLASTER OF PARIS	SHRIRAM, SAKARNI, BIRLA,J.K
13	PUTTY	ASIAN PAINTS., JK, BIRLA
14	EXPANSION BOLTS FOR FIXING	DASH FASTENERS OF APPROPRIATE SIZE BY HILTI OR EQUIVALENT
15	WINDOW HARDWARE	HETTICH, KAFF, EBCO OR HAFFLE
16	CERAMIC TILES	JOHNSON,SOMANY,KAJARIA, VARMORA,
17	VINYL FLOOR	ARMSTRONG/ RIKVIN , WONDER FLOOR
18	VITRIFIED TILES	JOHNSON, SOMANY, KAJARIA , VARMORA , SIMPOLO(WHITE BASE)
19	GLAZED TILES	JOHNSON , SOMANY, KAJARIA , VARMORA
20	SPECIAL CERAMIC TILES	SARASWATI CERAMICS, OTHER APPROVED POTTERY IN DELHI / KHURJA
21	HINGES AND DRAWER SLIDE, KEYBOARD	KAFF, HETTICH, OZONE, HAFFLE, EBCO
22	LOCKS, HANDLES	GODREJ, DORSET, DORMA, ASPA
23	DOOR CLOSERS, FLOOR SPRING, DOOR STOPPER AND HARDWARE FITTING	DORMA, DORSET, OZONE, GODREJ
24	ALUM, TOWER BOLTS, MAGNETIC CATCHER HARDWARE FITTING,	EBCO, EVERITE, SIGMA ,HETTICH, NIKON
25	MS SCREW	NETTLE FOLD, CALIBER, ARASNA, SUPERMAX
26	M.S. PIPES (RAILING)	JINDAL , APOLLO
27	FLUSH DOORS	DURO, CENTURY, GREENPLY, ARCHID
28	VENEER	DURO, CENTURY, GREEN
29	LAMINATE	GREENLAM, CENTURY, ARCHID
30	PLYWOOD, BLOCK BOARD	DURO, CENTURY, GREEN, ARCHID
31	STRUCTURAL STEEL	SAIL, TISCO, JINDAL
32	TEXTURE TILES FOR FALSE	ARMSTRONG, EVEREST INDUSTRIES LTD.

Tender Documents for proposed Furnishing & allied works for BO Dhaura Tanda

	CEILINGS / FIBER CEMENT BOARD	
33	WOOD	TEAK WOOD FIRST CLASS OF CP OR BURMA
34	M.S. ALUMINIUM LINEAL CEILING	INTERARCH, VISTA.
35	VENETIAL BLINDS	TRAC, VISTA, MAC, HUNTER DOUGLAS
36	GYPBOARD CEILING	GYPSUM INDIA, LAFAARZ., ST. GOBAIN
37	HEAT REFLECTIVE FILM	GARWARE, 3M, SUNBIRD, WISDOM
38	ADHESIVE	FEVICOL SH, CENTURY, VEMICOL, JIVANJOR
39	TILE ADHESIVE	UNITILE, ROFF CHEMICALS, KAJARIA
40	MIRROR	ATUL, JOLLY, MODI GUARD, ASAHI
41	G.I. PIPE AND FITTINGS	TATA, JINDAL, APOLLO, UNIK
42	WASTE & VENT PIPE & FITTINGS	JAYASWAL NECO (NAGPUR), C.I.A.L. (DURGAPUR)
43	WOOD PRESERVATIVE	WOOD GUARD OR APPROVED EQ/ICI
44	ALUMINIUM COMPOSITE SHEET	ALUCOBOND, ALSTONE, EUROBOND
45	ALUMINIUM SECTIONS	JINDAL, INDAL, HINDALCO
46	C.I./R.W.P.	NECO, RIF, IIS OR EQ
47	C.P BRASS FITTING	JAGUAR, PARKO, PARRYWARE, GROHE, KOHLER
48	SANITARY WARE	HINDWARE, PARRYWARE, JAGUAR, GROHE, KOHLER
49	STAINLESS STEEL SINK	DIAMOND, NIRALI, JAYNA, NILKANTH
50	SANITARY FITTINGS VISIBLE	JAGUAR, GROHE, KOHLER, PARRYWARE
51	PVC, U.P.V.C PIPE	SUPREME, PRINCE, ASTRAL, FINOLEX
52	CI BRASS LA PIPES	ELECTRO STEEL, KESORAM
53	STONE WARE PIPES	BHASKAR, ANAND
54	R.C.C PIPES	ISI MARKED OF APPROVED QUALITY
55	LOFT TANK	SYNTAX, UNIPLAS, PLOYION
56	CI PIPES & WORK	NECO, RIF, SIF, BIS OR EQUIVALENT ISI MAKE
57	ANTI TERMITE	THIDDAN (35 E.C.), DURS BAN – 20 TC, TRISHUL
58	GATE VALVES	LEADER, ZOLOTO
59	PLASTIC W.C SEAT COVER	COMMANDER, DIPLOMAT
60	GUN METAL VALVE (FULL WAY CHECK & GLEBE VALVES)	LEADER, SANT, ZOLOTO
61	C.I VALVE (FULL WAY CHECK & GLEBE VALVES)	KIRLOSKAR, LEADER, ZOLOTO
62	CPVC	PRINCE, ASTRAL, FINOLEX, SUPREME
63	READY MIX CONCRETE	ACC ULTRATECH, RMC INDIA, LAFARGE
64	THERMOFORMED	DUPONT, LG, AVONITE
65	CHAIRS/SOFA	
i)	WAITING BENCH FOR RURAL/ SEMI URBANSS FRAMED SEAT AND BACK WITH SS FRAME AND BASE FINISHED	GODREJ, METHODEX, FEATHERLITE, AFC, GEEKAY
ii)	SEATING OR SOFA SHALL BE WITH CUSHIONED BACK AND SEATS SHALL BE MADE IN LEATHER	GODREJ, METHODEX, FEATHERLITE, AFC, GEEKAY

Note: 1. Architect/ Bank reserves the right to select the approved make from the above list and to make changes (Add or Delete names of other makes) in this list with consent of Bank.

- Vendor should quote the rates of items considering FIRSTMAKE only.

All materials shall be of the first quality (among the approved brand, selecting brand shall be done as per Bank/Architect choice).

SPECIFICATION FOR ELECTRICAL WORK & ELECTRICAL WIRING

Supply & wiring for light, fan, call bell and 5 A plugs point and power plug point with necessary Amp. Capacity with 1.5mm PVC insulated copper conductor cable recessed. 1.5mm thick rigid PVC conduit with junction boxes & fan hook plate type switches and lugs all fitted in concealed 16 gauge sheet boxes embedded in wall cover of approved shade including continuous running of same PVC copper wire for earthing and wiring of sub-circuit main from the distribution board as per drawing and specifications as per required.

NOTE: All wiring points “light & power” shall include wires, conduits boxes, plate type switches and J. B. earth wire etc. complete as required.

- Wiring as per above specification for light point/tube light/exhaust fan/PL light.
- Wiring as per above specification for ceiling (including fan holder box) and hum free electronic regulator.
- Wiring as per above specification for universal type 6A plug point including earthing the 3rd pin in board with other lighting point or separate plug point.
- Wiring as per above specification for call bell point.
- Providing and installing telephone plug socket with board.
- Separate piping to be used for lighting, telephone, TV systems, power plugs, etc.
- Standard colour code system to be used in wiring.
- Entire wiring to be carried out as per ISI standards.
- Electrical wiring plans to be submitted as built by the contractor.
- All the testing for the appropriate period to be carried out on the behalf of site engineers.
- All the necessary approvals of local authority such as Electricity board, Electric Inspectors to be taken by the contractor. No additional charge will be paid to the contractor for the same. Only actual charge will be paid on receipts.
- Only certified and authorized contractors are valid to work onsite.
- List of worker to be submitted by the contractor with license and permit numbers.

FITTINGS & FIXTURES

- Supplying & fixing 1 X 40 W box type or mirror optic fluorescent luminaries complete with capacitor, copper wound choke, starter, lockable holders and lamp etc. including connections as required.
- Supplying & fixing musical door bell suitable for 230 V AC supplying including
- Connection as per required.

EARTHING

- Supplying & laying 8 SWG copper wire along sub-main conduit in recess as required.
- Earthing with copper earth plate 600mm X 600mm X 3mm thick including accessories and providing masonry enclosure with cover plate having locking arrangement and watering pipe etc. including providing salt and charcoal etc. as required.
- Supplying & laying 25mm X 6mm copper strip in 40mm dia. G. I. pipe from earth electrode as required.

Tender Documents for proposed Furnishing & allied works for BO Dhaura Tanda

COMPUTER DATA CABLING WORK

Computer wiring shall be done with CAT-6 cable. The unit rate shall be considered on running meter basis including supply, laying, connection, testing and commissioning of computer data cable. The wiring shall be done through in 1.2mm thick PVC conduit for computer outlet point including supply and fixing of terminal junction box, outlet boxes, cover plates of RJ-45 with I/O connection for computers, networking rack.

SCHEDULE OF APPROVED MAKES FOR MATERIALS IN ELECTRICAL WORKS

ALL MATERIALS USED MUST HAVE ISI & FIA APPROVED

S. NO.	ITEM	COMPANY MAKE
1	MEDIUM VOLTAGE SWITCHGEAR	
a	MOULDED CASE CIRCUIT BREAKER	SCHNEIDER / LEGRAND/ SIEMENS, L&T HAGGAR, HAVELLS (MCCB)
b	SWITCH FUSE UNIT	HAVELLS / L & T/ EE/ CROMPTON / H HELCON
c	HRC FUSE	HAVELLS/ L & T/ EE/ H HELCON
d	CHANGE OVER SWITCH	HAVELLS/ L & T, SEIMENS
2	VRF/VRV AC System	DAIKIN /O GENERAL / HITACHI
2(a)	Split AC	DAIKIN /O GENERAL / HITACHI (INVERTER AC)
3	CENTRIFUGAL FANS	KRUGER/NICOTRA/ GREEN HECK/AIR FLOW
4	INLINE FANS	KRUGER/NICOTRA/ GREEN HECK/AIR FLOW
5	G.I. Sheets	SAIL/ TATA/JINDAL
6	FACTOR FABRICATED DUCTING	ROLASTAR/ZECO/DUCTOFAB
7	WELDING ROADS	ADVANI/L&T
8	DUCT SUPPORTS	HILTI/ WALRAVEN/GRIFFLE
9	ANCHOR/ FASTENER	HILTI/FISHER/STERLING
10	ALUMINIUM TAPE	JOHNSON/BIRLA/ 3M
11	GRILLS/DIFFUSERS/FIRE DAMPERS	GLENSTORMS/SYSTEMAIR/RUSKINTITUS
12	INSULATION/ACOUSTIC LINING FOR DUCTING	ARMACELL / UROBATEX /VIDOFLEX
13	INSULATION FOR REFRIGERENT FOR PIPE	ARMACELL / UROBATEX /VIDOFLEX
14	COPPER REFRIGENT PIPE	RAJCO/MANDEV/MAHFLOW
15	UPVC DRAIN PIPE	SUPREME/ASTRALS/FINOLEX
16	CANVAS CONNECTION	MAPRO/GLENSTORMS/ASTAR
17	PROPELLER TYPE EXHAUST FAN	KRUGER/ HAVELLS/ MARATHAN/ORIENT/USHA/BAJAJ
18	MCB/ELCB/DBS/MCCB	SCHNEIDER / LEGRAND/ SIEMENS, ,L&T HAGGAR, HAVELLS
19	ACB	SCHNEIDER (MG-NS SERIES)/ SIEMENS (3WT)/ L&T (D-SINE)
20	MV CONTRACTORS/TIMER/ STARTERS	L&T/ SIEMENS/LEGRAND
21	PROTECTIVE RELAYS	L&T/ SIEMENS, ALSTOM, ABB
22	ALL METERS	ENERCON/NEPTUNE/ SIEMENS
23	AMMETER/VOLTMETER	A.E/ INDOTECH OR APPROVED EQUIVALENT
24	INDICATION LAMPS/PUSH BUTTON	L&T/ SCHNEIDER/VASHINO,CONCORD,SIEMENS
25	CAPACITOR	L&T/ SIEMENS/ NEPTUNE
26	TERMINAL BLOCKS	ELMEX/WAGO/CONNECT-WELL
27	CURRENT TRANSFORMER	AEP/ KAPPA/ INDITECH
28	SELECTOR SWITCH	KAYCEE/L&T/BCH/AREVA/ABB
29	BUS BAR	JINDAL/ INDALCO/ CENTURY
30	LT CABLES/CONTROL CABLE	SKYTON/ FINOLEX/POLYCAB /GLOSTER ALL FRLS

Tender Documents for proposed Furnishing & allied works for BO Dhaura Tanda

31	SWITCH SOCKET/METAL CLAD SOCKET	LEGRAND (MYRIUS) , / ANCHOR ROMA , HAVELLS (CRABTREE)
32	CABLE TRAY	PILCO/ NEEDO, SLOTCO, VENUS, ERA CONTROL SYSTEM
33	HUNGS	DOWELS
34	CONNECTORS	ELMEC/DELCCITY/WAYTEK
35	CABLE GLAND	STRIPWELL/ COMMET/ SIEMENS, GROMMET, POWER ENGG
36	MV PANEL (TTA)	SIEMENS CPAN/ ABB R2K/ SCHNEIDER BLOCKSET
37	GI CONDUIT	BEC/ AKG/ STEEL CRAFT
38	MOTORS	SIEMENS/ ABB/ CROMPTON
39	PVC PIPE	FINOLEX/ PRINCE/ SUPREME
40	ELECTRICAL PANEL	KRYPTON/RISHA/KEPL, ERA CONTROL SYSTEM /SPT
41	G.I PIPE	TATA/JINDAL/BHUSAN
42	EARTH LEAKAGE CIRCUIT	HAGER/ LEGRAND/ MERLIN GERIN
43	FIRE ALARM SYSTEM	SYSTEM SENSOR/ EDWARDS/APPOLO/AGNI
44	DATA COMPONENTS	AMP/ SYSTMATICS/LEGRAND
45	ACCESS CONTROL SYSTEM/ CCTV SYSTEM	BRIVO/HONEYWELL/DATS/LENEL/TYCO/SIEMENS
46	DOOR PHONE	PANASONIC/ZICOM/SOLUS(SECURE)
47	READER	BRIVO/HID
48	SMART PROXIMITY CARD	BRIVO/HID
49	CAPACITOR BANKS	L&T/ SIEMENS/ALSTOM
50	PVC INSULATED COPPER CONDUCTOR	FINOLEX/ POLYCAB FRLS/HAVELLS
51	CONTROL WIRES OF 1100 V GRADE COPPER LUGS HEAVY DUTY	DOWELLS
52	MEASURING METERS	AUTOMATIC ELECTRIC/KAPPA/ENERCON
53	DIGITAL METERS & KWH METERS	SECURE/L&T/ENERCON
54	PUSH BUTTONS	L & T/SIEMEN/ABB
55	WIRING CABLE	FINOLEX / POLYCAB / HAVELLS/RR CABLES ALL FRLS
56	M.S. CONDUITS AND ASSESSORIES	BEC /AKG /ESC
57	P.V.C. CONDUITS AND ACCESSORIES	BEC/ AKG/POLYPACK/ESC ALL FRLS
58	LIGHT FIXTURES	PHILIPS/HAVELLS/SYSKA/WIPRO
59	FAN	USHA/CROMPTON/HAVELLS
60	ANY OTHER ITEMS	SAMPLE TO BE APPROVED BY BANK/ARCHITECT

ALL THE LIGHTING FIXTURES & LAMPS AND CEILING/WALL/EXHAUST FANS WILL HAVE THREE STAR RATING.

Note:

1. ARCHITECT reserves the right to select the approved make from the above list and to make changes (Add or Delete names of other makes) in this list with consent of Punjab and Sind bank .
2. Vendor should quote the rates of items considering FIRST MAKE only.

FINANCIAL BID

SUMMARY SHEET BOQ FOR INTERIOR FURNISHING, ELECTRICAL, DATA CABLING & AC WORKS		
AT NEW PREMISES FOR NEW BRANCH DHAURA TANDA, PUNJAB AND SIND BANK		
Sr. No.	Description of Work	Amount in Rs.
1.	Furnishing work (Branch + ATM)	
2.	Electrical, Data Cabling (Branch+ATM)	
3.	AC Work (Branch + ATM)	
	TOTAL	
	Special Discount (if any)	
	FINAL TOTAL AFTER DISCOUNT	
RUPEES		

पी.एस.बी

Financial Bid for proposed Interior works for B.O. Dhaura Tanda

Detailed Estimate for Proposed Furnishing work in the premises of PUNJAB & SIND BANK, at Branch & ATM Office at Dhaura Tanda Distt Bareilly .					
Item No.	Description	Qty.	UNIT	Rate	Amount
	A- Branch Office				
1	STANDARD RUNNING COUNTERS				
	Providing, fabricating and fixing at site and in position modern Clerical/Cashiers Counters as per enclosed detailed drawing consisting of 19mm thick ARCHID, KANCHAN, LIBERTY or equivalent approved make commercial finished borer and termite resistant block board having 10 to 15" wide transacting top at 42" height and 30" wide writing/work top at 30" height from the finished floor level. The work top shall be supported by the drawer unit of standard size housing 4" to 5" deep drawer for clerical counter and 3 nos. 8" deep drawers in Cash Counters running on approved make Channels as directed by Bank, placed at every 3.6" to 4'0" for CLERICAL COUNTERS and every 4'-0" for CASH COUNTERS or as per approved layout plan and consisting of 19 mm thick commercial finished block board of above specified makes. The frontside (Public side) of the counters shall be consisting of 19mm block board of approved makes for entire and length of the counter. The transaction top, writing/work top and front/public side face of the counter and front face of the drawer cum cupboard unit shall be finished with White/Creame Cedar/Pear Tree Wood Grain lamination as per sample approved by Bank. The public side of the counter shall be provided with 19 mm thick laminated blockboard skirting 100mm high. The rate should include providing and fixing seasoned t.w. beading of finished size 19mm x 4 mm or as required to all exposed edges of the block board. Each cupboard/ drawer shall be provided with approved quality 1no. handles/knobs and 1no. GODREJ or equivalent approved quality cupboard locks. All exposed and un-exposed faces of teak wood, BWP block board shall be polished/painted with 3 or more coats of approved quality and shade french polish/enamel paint to have desired finish. The rate should also include providing and fixing 19mm thick approved quality block board support of required size at size at the starting & end of the counter duly laminated with similar quality and shade lamination and also closing the first and last counter and also providing and fixing 2.5"x 1.5" seasoned wood foot rest of required length to each counter complete as per the layout plan and as directed by Bank's Engineer.				
	(a) Cash counters	5.25	RFT		
	(b) Clerical counters	12.0	RFT		

Financial Bid for proposed Interior works for B.O. Dhaura Tanda

2	Supply & Fixing of 12 mm glass with etching (design as per Architect) in wooden pillar with polish all complete. in cash cabin front , working counter , and manager table top	90.75	SQFT		
3	Supply & fixing of Alluminium gril one cash cabin Top & Sides	60.00	SQFT		
4	FLUSH DOOR SHUTTER WITH GLASS				
	Providing and fixing 40 mm thick solidcore flush Door shutters of ARCHID / KANCHAN / KANCHAN or equivalent ISI make as per sample approved by the Bank finished with approved quality and shade 1.0 mm thick lamination on both side of the shutter with matching wood beading duly melamine polished. The rate should include the following:-				
	(i) Providing 8 mm thick float glass of 3' to 4' height fixed at 3' above the floor level with suitable beadings.				
	(ii) Providing 4" high skirting with 1.0 mm sunmica lamination on both sides and TW lipping to edges.				
	(iii) Applying anti-termite/boarer treatment/paint to door shutter wherever directed.				
	(iv) Providing 4Nos -4"x1.5" Brass Oxidised Hinges, anodised aluminium Handles, tower bolt, etc. as per samples approved and as per site requirements.	66.50	SQFT		
5	TABLES Providing in position Officer's tables of sizes mentioned hereinafter. It shall consist of 19 mm thick commercial block board of ARCHID / KANCHAN or equivalent approved make on the top finished with 1.00mm thick approved quality lamination as per sample approved and as per design/detail. The writing top shall be supported over two vertical supports made out of 19 mm thick commercial board of above specified makes with lamination as above. The supports shall be connected together with 19 mm thick commercial board duly laminated front as per approval and design/ detail. The table shall be complete with drawers, shelves, necessary hardware, knobs, Godrej locks etc. as per detailed drawing and samples approved. The rate to include applying 3 coats of melamine spray polishing /painting etc., plastic shoes complete.				
[i]	Table of size 6'-0" x 3'-0"x2'-6" height with Table top as per detailed drawing	1	NOS.		
[ii]	Table of size 5'-0"x2'-6"x2'-6" ht. as per detailed Drawing	2	NOS.		

Financial Bid for proposed Interior works for B.O. Dhaura Tanda

[iii]	Table of size 4'-0"x 2'-6" ht. as per detailed drawing.	1	NOS.		
6	SIDE TABLES				
	Providing and fixing in position side tables of sizes mentioned hereinafter. It shall consist of 19mm thick commercial board of KANCHAN / ARCHID or equivalent approved make in top, middle shelf, bottom and sides as per detailed drawing. The top and sides shall be laminated with 1 mm thick approved quality and shade laminate as per design detail. The cabinet shall be covered from back with 6 mm ply of ARCHID / KANCHAN or equivalent approved make. The rate should include for providing 19 mm laminated block board shutters and necessary hardware, knobs sliding channels, Godrej locks etc. as per samples approved complete with applying 3 coats of melamine polishing / painting to un-laminated surface inside / outside, plastic shoes and also providing and fixing 19x4mm suitable teak wood/ inlay beading to all exposed edges to the block boards etc. as per Bank's approval.				
[a]	Side rack of size [3'-0"x2'-6"x1'-6" x 1 + 9'-6" + 2'-6" x 2'-6" x 1'-6" x 2]	43.75	Sq.ft		
7	SOFA SET				
	Providing and fixing sofa made out of 19 mm thick Duro / Swastik/ Green block board and 2" x 2" seasoned wood frame. The seat shall have flat tensile spring, hessian base and 4" pin hole ISI grade rubber foam pin-hole cushions of Prestige or equivalent approved make with 1"-37 density foam. The Back shall have 3"- 37 density U-foam. Sofa shall be upholstered with tapestry upto Rs. 150/-per mt. as per sample and colour / shade approved by the Bank's authorities.				
	THREE SEATER		NOS.		-
	TWO SEATER		NOS.		-
8	FALSE CEILING [a] GYPSUM				
	excluding Record & Strong Room				
	Providing and fixing Wall angle application wall Angle is fixed at periphery of wall/partition with rawl plug/screws 22x22x0.40x3000mm 19x19x0.40x3000mm Main-T-				
	Application The main runner supports the installation of cross-tees from one simple inventory of main runners.				
	The system is available in both 24mm and 15mm width.				
	The Main Runner with clip provide a quick and easy assembled main runner to main runner connection				

Financial Bid for proposed Interior works for B.O. Dhaura Tanda

	38x24x0.30x3000mm 38x24x0.25x3000mm				
	325x15x0.30x3000mm Cross-T-Application Cross-tee				
	to be inserted in Main T-Section to form modules of sizes				
	600x600 and 600x1200 to lay in tile of required sizes.26x				
	24x0.30x1200mm 26x24x0.30x600mm 26x24x0.25x1200				
	mm 26x24x0.25x600mm 32x15x0.30x1200mm 32x15x0.				
	30x600mm Star Pin/Sky Fissured Size-600x600				
	Thickness-12mm/15mm RH-95/99 all complete	362.5	SQFT		
[b]	MODULER FALSE CEILING : Armstrong / equivalent				
	make, Providing and Fixing Armstrong [Fine Fissured				
	Micro Lock with Tagular Edge using 15mm Grid				
	sections] False ceiling of size 24"x24" at levels as				
	show in the drawing From FFL Rate shall be inclusive				
	of providing the total system with installation etc. The				
	contractor has maintain all tiles in good order and				
	replace the defected tiles [at his own cost] before				
	handing over the site for Branch operations				
	[Till Inauguration]	476	Sq.ft		
9	MORTISE LOCK				
	Providing and fixing in position DOORSET 6 lever cylindrical lock				
	silver/brass finish as approved by the Bank.	2	NOS.		
10	VOUCHER WRITING TABLE				
	Providing and fixing Voucher writing table with about 5				
	voucher slots/pockets as per the detail drawing consi-				
	sting of 19mm block board of ARCHID/GREEN/KANCHAN				
	or equivalent approved makes duly laminated using				
	1.0 mm laminate of GREEN/ROYAL TOUCH or equiv-				
	alent approved by the Bank having slanting top and				
	waste paper box with dumping and cleaning window in				
	the lower supporting cloumn including polishing/enamel				
	painting etc.complete.	1	NOS.		
11	SOFA /SETTEE SIDE TABLES				
	Providing and fixing in position side table of size given below made				
	out of 19mm thick specified make commercial block board finished				
	with 1.00mm laminate on sides complete as per detailed drawing				
	including providing 19mm approved colour profiled/bevelled edge				
	machine polished granite stone on the top, polishing of TW lipping				
	etc..				
	(a) 1'6"x3.0'x1'6" ht.	0	NOS.		
12	M.S. G.I. GLAZED & PANELLED PARTITIONS				
	(FLUSH TYPE) with M. S. frame work - Cash cabin -7'6" ht &				
	Manager - 9'-0" ht				
	7'-6" ht , Manager Cabin Up to 9'- 0" Providing and fixing partitions				
	made out of 45 mm x 45 mm G.I.Channel Frame @ 1' 6" c/c				
	horizontally and 2' c/c vertically with Water proof and anti termite 8				
	mm exterior grade MDF				

Financial Bid for proposed Interior works for B.O. Dhaura Tanda

	Make : Action Tesa with 1.00mm approved quality and shade lamination with Teak wood moulded beading on both side duly melamine polished. The partition will be provided with 8 mm thick float glass of 4' height fixed at 3' above the floor level in average 3' wide panels. The rate should also include providing 4" high skirting of 12mm BWP ply with 1mm aica lamination on both side including applying anti-termite /boarer paint to wooden framework wherever directed.	291.25	SQFT		
13	LOW HEIGHT WOODEN PARTITIONS UP to 5'-0" ht Providing and fixing in position low height M.S.partition as per item no. ... above upto 4 ft height but upper 10/12" portion of partition will have 8mm thick plain or tinted float glass of MODI/TRIVENI with etching and remaining lower portion to be panelled with 8mm thick Action Tesa MDF Board duly fixed with suitable beading. The top of the Partition shall be provided moulded beading made out of 65x25mm	67.5	SQFT.		
14	PLANTER BOX Supplying Planter box consisting of 19mm commercial board 15"x15" finished with 1.00mm laminate from outside and including polishing etc.all complete.	0	NOS.		
15	NOTICE BOARD 6'x3' x 0"-4" deep complete all respects	1	NOS.		
16	ALUMINIUM DOOR SHUTTER WITH GLASS Providing and fixing partly fixed/opens aluminium door shutters consisting of JINDAL or equivalent approved make Powder coated aluminium section no. 4504 for door vertical styles, section no. 4541 for door bottom rail, section no. 4531 for middle/ lock rail and section no. 4542 for top rail weighing approx. 0.976 Kg/m, 2.122 Kg/m, 0.989 Kg/m and 1.533 Kg/m respectively suspended /supported on the floor spring and pivot of EVERITE or HARDWYN make only, 2 nos. approved quality aluminium handles and one 6-lever Godrej make six lever mortice lock/night latch in each shutter. The measurements of shutter area only shall be measured and requisite door frame shall be measured as a part of partition only. powder coating of approved quality all complete.	49.50	SQFT		
17	DOOR CLOSER Providing & fixing door closer of EVERITE as equalent make all complete.	3	NOS.		

Financial Bid for proposed Interior works for B.O. Dhaura Tanda

18	WALL PANELLING in Manager & Cash Cabin & Interoe Col. Providing and fixing wall panelling consisting of seaso- Approved quality M.S. G.I. frame work made out of 2"x1"sections placed at 15 to 18" centre to centre firmly fixed to wall covered with 8 mm MDF Board of Make Action Tesa / Merino Finished with 1.0mm thick approved quality and shade lamination in appr- oved pattern and design including providing T.W. mo- oulded beading at top ends or as directed, polishing etc. complete.	273.00	SQFT.	
19	SUGGESTION BOX 12"x9"x9" deep complete in all respects	1	NOS.	
20	ELECTRIC PANEL BOX Providing and fixing 3'-6" x 7'-0" x 9" consisting of 19mm commercial board finished with 1.00mm laminate from outside and including enamel painting etc.all complete.	1	NOS.	
21	CHEQUE DROP BOX 12"x9"x9" deep complete in all respects .	1	NOS.	
22	NIGHT LETCH LOCK Providing and fixing in Cash Cabin Door all complete	1	NOS.	
23	FLOORING P/L Vitrified floor tiles (Jointless) of standard manufactured in 24" x 24" size (thickness to be 10mm with water absorptions less than 1% and flaxural strength not less 30N/sqmm in all colours and shade, laid on 20mm thick cement mortar 1:4 (1 cement :4 coarse sand) including gROUTING the joints with white cement and maching pigments etc., complete including supply of material labour T & P required for the proper completion of the work.			Work done by owner
24	PAINTING Painting on walls and ceiling with plastic emulsion paint after preparing the surface. Complete in all respect with two or more coats.			Work done by owner
25	Painting with enamel paint after cleaning treting the surface with suitabale primer over steel work such as window grill, chennel shutter etc.			Work done by owner
26	Painting of external wall with APEX Paint			Work done by Owner
		Total (A)		-
[B]	FURNISHING WORK :- ATM			

Financial Bid for proposed Interior works for B.O. Dhaura Tanda

1	FALSE CEILING - P/F Suspended false ceiling made of Armstrong / Legstrong fisher per coated board with powder coated aluminium Grid [600 x 600] mm with necessary hanger. Elean other accessories as per manufacturer's specification .	54.00	Sq. ft		
2	FLOORING - P/F of vitrified tiles of approved quality size a shde and design to floor laid in panels and patterns and set laid on 20mm thick cement mortar 1:4 [1 cement : 4 coarse sand] including filling joints with epoxy grout of matching color complete . Makes - JOHNSON / SOMAY / EURO / ASIN , SIZE - 600 X 600 MM	0.00	Sq. ft		Work done by Owner
3	ALUMINIUM DOOR SHUTTER WITH GLASS Providing and fixing partly fixed/opens aluminium door shutters consisting of JINDAL or equivalent approved make Powder coated aluminium section no. 4504 for door vertical styles, section no. 4541 for door bottom rail, section no. 4531 for middle/ lock rail and section no. 4542 for top rail weighing approx. 0.976 Kg/m, 2.122 Kg/m, 0.989 Kg/m and 1.533 Kg/m respectively suspended /supported on the floor spring and pivot of EVERITE or HARDWYN make only, 2 nos. approved quality aluminium handles and one 6-lever Godrej make six lever mortice lock/night latch in each shutter. The measurements of shutter area only shall be measured and requisite door frame shall be measured as a part of partition only. powder coating of approved quality all complete.	35.00	Sqft		
4	WRITING LEDGER - P/F Writing ledge made of 12mm thick plate glass with SS with cantilever type glass holding bracket - 900mm 300mm .	1	No		
5	WALL PANELLING - Wall paneling with ACP as per approved color & designed fixed with [50 x 25mm], 2mm thick aluminium tube in plum including jointing tape with ALUBOND / GURING to external / internal wall surface and soffit below signage Board .	254.00	Sq. ft		
6	PAINT - Providing 2 coats of plastic emulsion paint [of approved colour] over a coat of cement primer to inside of UPS Room .	0.00	Job	L.S.	Work done by

Financial Bid for proposed Interior works for B.O. Dhaura Tanda

				Owner
7	ETCHING - PSB Monogram with etched film on the Main door . [as approved by Bank] .	9.04	Sq. ft	
8	CHEQUE DROP BOX - P/F one cheque drop box made out of 12mm thick board duly laminated with all hardware fitting and fixtures Size 400 x 300 x 100mm .	1	No	
9	POSTER DANGLE - Supplying and fixing 6mm thick double acrylic sheet fixed with SS stud on wall of size 650 x 500mm as per standard .	1	No	
10	PAMPHLET RACK - P/F 6mm thick acrylic sheet rack of size 650 x 3500 x 50mm as per standard fixed with SS stub	1	No	
11	SHUTTER BOXING : Branch & ATM Providing & Fixing in position Aluminium Composite Panel [ACP] with framing of Aluminium Tube sections of min 1.5" x 1" and 20 gauge 2'-0" C/C both ways. Mirror screws to be used. Joints to be finished with Silicon based sealant. ACP thickness of 3mm minimum. Aluminium foil thickness to be min 0.20 mm ., 2'-0" C/C both ways. ACP to be in 2' width panels or distributed equally. Alubond, Eurobond, Fujibond, Alcobond or equivalent ISO certified brands to be used . Shades to be as per Bank's standard colours: with ACP Trap door .	278.50	Sq. ft	
	Total (B)			-
		Total (A + B)		

Financial Bid for proposed Interior works for B.O. Dhaura Tanda

Detailed Estimate for Electrical, & Date Cabling work in the Premises of Punjab & Sind Bank					
Branch & ATM Office at Dhaura Tanda Bareilly .					
S.No	DESCRIPTION OF ITEM	QTY	UNIT	RATE (Rs.)	AMOUNT (Rs.)
	A- Branch Office.				
1	Installation of 200Amp Kit kat Fuse unit 3 nos with 200 Amp neutral link on wooden board (3feet x 3feet') complete with connections (new).	1	Set		
2	<u>ELECTRICAL PANEL</u> Design, manufacture, providing, storing & installing in position, effecting proper connection, testing and commissioning of panel made of 16 SWG, CRCA sheet steel. It shall be dust and vermin proof. It shall have compartmentalized construction with bus bar chambers, cable alley, cable glands plate etc. as required, duly painted from inside as well outside. shall have the following - Incomer : 1 No. 125 Amp. TPN, MCCB (18 KA breaking capacity), Busbars, (100 Amp, 3 phase, 4 strips, 415 volts, 50 Hz. copper busbars with colour coded PVC heat shrinkable sleeves.) Instruments. Multi function Meter for Voltage, Ampere, Power factor, KWH, Data 1 No Outgoing : 6 Nos. 63 Amp. TP, MCB (For LDB, PDB, Branch UPS DB, ATM UPS DB and Spare Feeder) No., 125 Amp. Four Pole Change Over for D.G. Set. Seperate from the panel, The design of panel should be got approved by the Architect before manufacturing. The job shall be completed, to the satisfaction of the Bank Engineer/Architect.	1	Nos		
3	<u>UPS I/P, O/P AND DISTRIBUTION</u>				
A	20/32 AMP Metal industrial socket along with MCB for UPS I/P and O/P .	3	Nos		
B	12 WAY SPN DB Double Door [1 No. 40AMP DP MCB and 10 Nos. 6-10 AMP SPMCB] Branch UPS Power Distribution]	1	No.		
C	SITC OF 63 AMP TP MCB in M.S. Encloser complete in all respects as required. [Branch UPS]	1	No		
E	SITC of 63 AMP Rotary Phase selector switch complete with RYB indication fitted in M.S. Encloser complete in all respects as required. [Branch UPS] .	1	Nos		

Financial Bid for proposed Interior works for B.O. Dhaura Tanda

4	RAW POWER & FAN, LIGHTING DB & AC DISTRIBUTION BOARD				
A	4 WAY TPN DB Double Door Concealed in wall (1 No. 63 AMP TP MCB and 12 NOS. 6-32 AMP. SPMCB) (1 DB for Raw Power & 1 DB for Light + Fan) all complete with blanking plates.	2	Nos		
B	4 WAY TPN DB Double Door Concealed in wall (1 No. 63 AMP FP MCB and 9 NOS. 16-32 AMP. SPMCB) (For Branch AC) all complete with blanking plates	0	Nos		
5	CABLES				
A	4 X 4.0 Sq.mm Copper Wire + 1X 2.50 Sqmm copper earth wire in PVC Pipe fixing on walls or chassing the walls and making it good with cement mortar of 1:5 ratio including Connecting, testing etc. compete (Panel to UPS Incomer, LDB, PDB)	25	Mtr.		
B	Same as above but 4 x 10.0Sqmm + 1 x 4.0 Sqmm Copper Counductor Cable. (Kit Kat fuse unit to AC DB) complete with CU lugs at both ends.	20	Mtr.		
C	2 X 4.0 Sq.mm Copper Wire (ROTARY SWITCH TO UPS TO DB) + 1X 2.5 Sqmm copper earth wire in PVC Pipe fixing on walls or chassing the walls and making it good with cement mortar of 1:5 ratio including Connecting ,testing etc. Compete	25	Mtr.		
D	2 X 2.5 Sq.mm Copper Wire (Electric Panel to ATM Light Board & Glow Sign Board) + 1X 1.5 Sqmm copper earth wire in PVC Pipe fixing on walls or chassing the walls and making it good with cement mortar of 1:5 ratio including Connecting , testing etc. compete with lugs	30	Mtr.		
E	Supply & Laying 35 x 3.5 Core AR PVC Sheathed cable with termination at both ends with lugs & fixing with clamps & accessores . (Electric meter to Electric panel)	20	Mtr		
6	AC (Split) POINT- Branch & ATM				
A	Point Wiring with 2 No. 4.0 Sq.mm and 1 No. 2.5 Sq.mm Multistrand Copper Wire & 32 Amp. Metallic plug & Socket DB complete in all respect as required by the Bank (for 1.5 Tr AC)	6	Nos		
7	EARTHING				
A	PIP technology GEL type 500mmdia 3000mm long earth electrod. (One Dedicated Earthing for UPS, One for Body earthing and one for neutral.)	2	Nos		
B	12 SWG Bare Copper Earth Wire from earthing pit /Earth terminal to load point (UPS DB and Main DB etc)	45	Mtr.		
C	G. I. Strip 25 x 3 sqmm Strip from Electrode to wall.	0	Mtr.		

Financial Bid for proposed Interior works for B.O. Dhaura Tanda

8	UPS POINT			
A	Supply & Installation of point wiring for UPS points on workstations / table for computers using 2 x 2.5 + 1 x 1.0 Sq.mm copper conductor multi stranded FR PVC sheathed flexible wire pulled through floor raceways/conduit and taken upto table top using PVC rigid or flexible conduits run with in metal partitions. Each point consisting of 2 nos of 10A , 3 pin sockets & 1No., 20A Switch with socket (Modular) on 8 Module Horizontal Plate, Blanking & Box. Wired together forming one point. The earth wire of green color only. (10 nos. from Branch UPS DB & 1 nos. from ATM UPS DB)	10	Nos	
9	RAW POWER POINT			
	Supply & Installation of point wiring for Raw power plug points on workstations / table for computers using 2 X 2.5 + 1 x 1.0 Sq.mm copper conductor PVC sheathed flexible wire Each point consisting of 1 nos of 20A , 6 pin socket & 1 No., 20A Switch (Modular) on 3 module Plate and box, wired together forming one point. The earth wire of green color only.	10	Nos	
10	Wiring for Circuit / Submain wiring along with earth wire with the following size of FRLS PVC Insulated copper conductor single core cable in surface/ recessed PVC Medium duty conduit:-			
a.	2 x 1.5 Sqmm + 1 x 1.0 Sqmm Earth wire	105	Mtr.	
b.	2 x 2.5 Sqmm + 1 x 1.0 Sqmm Earth wire	95	Mtr.	
c.	2 x 4.0 Sqmm + 1 x 1.5 Sqmm Earth wire	0	Mtr.	
d.	2 x 10.0 Sqmm + 1 x 4.0 Sqmm Earth wire	0	Mtr.	
11	LIGHT / FAN POINT			
	Supply & Installation of concealed point wiring using 600v grade 1.0 Sq.mm copper conductor PVC insulated wires (with proper R,Y,B color code) pulled through Medium gauge PVC conduits laid concealed over false ceiling including 2 Nos. 2.5 sqmm circuit wires from the relevant DB and also including 1.0 sqmm green color copper earth wire and switch plate, switches, etc. as approved by the Bank's Engineer/Architect.			
A	Primary light points including the cost of 10 A modular switch	55	Nos	
B	Secondary light points looped from the primary point	0	Nos	
C	Ceiling Fan Point including the cost of 10A modular Switch along with 4/5 step electronic fan regulator.	1	Nos	
D	Wall Fan Point along with 10 Amp modular switch on Board and 10 amp socket on two module plate near wall fan.	17	Nos	

Financial Bid for proposed Interior works for B.O. Dhaura Tanda

(B)	ELECTRICAL WORK :-ATM				
1	Point circuit wiring shall consist of Providing, fixing and laying cable with 3 core 2.5 Sqm [MAKE HAVELLS, FINOLEX, POLYCAB] insulated copper conductor in surface, recess complete in hard PVC conduit. Cost include modular type swirch socket cover plate and box of make ANCHOR / CRABTREE / MK as approved .				
1a	Light Point with 3 Nos x 1.5 Sqmm and circuit 2 No x 2.5 Sqmm + 1 No 1.5 Sqmm with modular switch socket with PVC conduit [ISI mark] .	12.00	No		
1b	6A. 5 Pin switch and socket with wiring 2 x 2.5 Sqmm + 1 x 1.5 Sqmm copper wire in PVC conduit [ISI Mark]	4.00	No		
2	Providing & Laying 3C 4 Sqmm PVC insulated Copper conductor single core cable complete earthing as required form existing main panel to UPS & AC .	30.00	Mt		
3	Earthing with copper earth plate [600 x 600 x 6] mm including accessories & providing masonry enclosure 600mm and deep up to and 40mm dia G.I. Watering pipe etc including charcoal or coke & salt as required . It also includes [25x5] mm copper earth strip in pipe up to ATM / VSAT complete as per IS 3043/87 with test result below 50mm .	One	Nos		
4	P/F 6 way SPN DB of make HAVELLS / LEGRAND				
[a]	Incomer - 40 A DP MCB - 1 no. B Outgoing - 10A / 20A / 25A - 4 Nos .	1	Set		
5	Dual System AC running with timer comprising of 32 A DB MCB 40 A Contactor 2 nos 25A MCB and 32A timer [24 hrs of Legrand L & T make .	1	Set		
6	Mirror Opties 2'x2' Mirror opties with lamp. Make philips code FBs 4501 x PL - 1 36 W IC M2 DG-GN or Havels make Decora code LH CC 70236127, Lamp 2 x 3 W FP - L [HF] .	1	No		
7	Downlight - PHILIPS MAKE FBH145 M2 x PL - C/2 P 18 W or Havels Make 2 x 18 W PLC Code LHOCO 4218354 .	10	No		
8	Spotlight - Havels Make 1 x WPL - C - LHOC141835 or Philips Make FBS 100 1 x PL -C/4P 18 W HFM 240 V.	1	No		
		Total (B)			-
		Total (A + B)			
Detailed Estimate For A.C. Work in the premisses & ATM of PUNJAB & SIND BANK at Dhaura Tanda ,Bareilly .					

Financial Bid for proposed Interior works for B.O. Dhaura Tanda

S.N	Description	Oty	Unit	Rate	Amount
	Branch area, excluding for Strong Room, Sanitary & Manager Cabin				
	= 714.50				
	120 Sq ft / ton we need = 714.50 = 5.95 Tone				
	= 120				
1	1.0 TR split in Manager Cabin & Atm (Invertor A.C)	3	No		
2	1.50 TR split in hall (Invertor A.C)	3	No		
3	M.S. stand - [In door & out door units]	6	No		
4	Installation Charges .	6	No		
5	Extra cost for Copper pipe / cable over .	60	Rmt		
6	PVC drain pipe .	40	Rmt		
7	Supply & fixng of 4.0 Kva 150 Volt Stablizar	6	Nos		
				Total Rs.	
	MAKE > Voltas / Carrier / Daikin / Five Star Rated				
	Manufacturing warranty > 1 year comprehensive on product, 5 years on PCB				
	and 10 years on compressor minimum, manufacturing year 2023/2024				
[1]	NOTE > All A C in door & out door Unit and Wiring dismentling and hand over to Branch head.				
[2]	NOTE > G. S. T EXTRA				



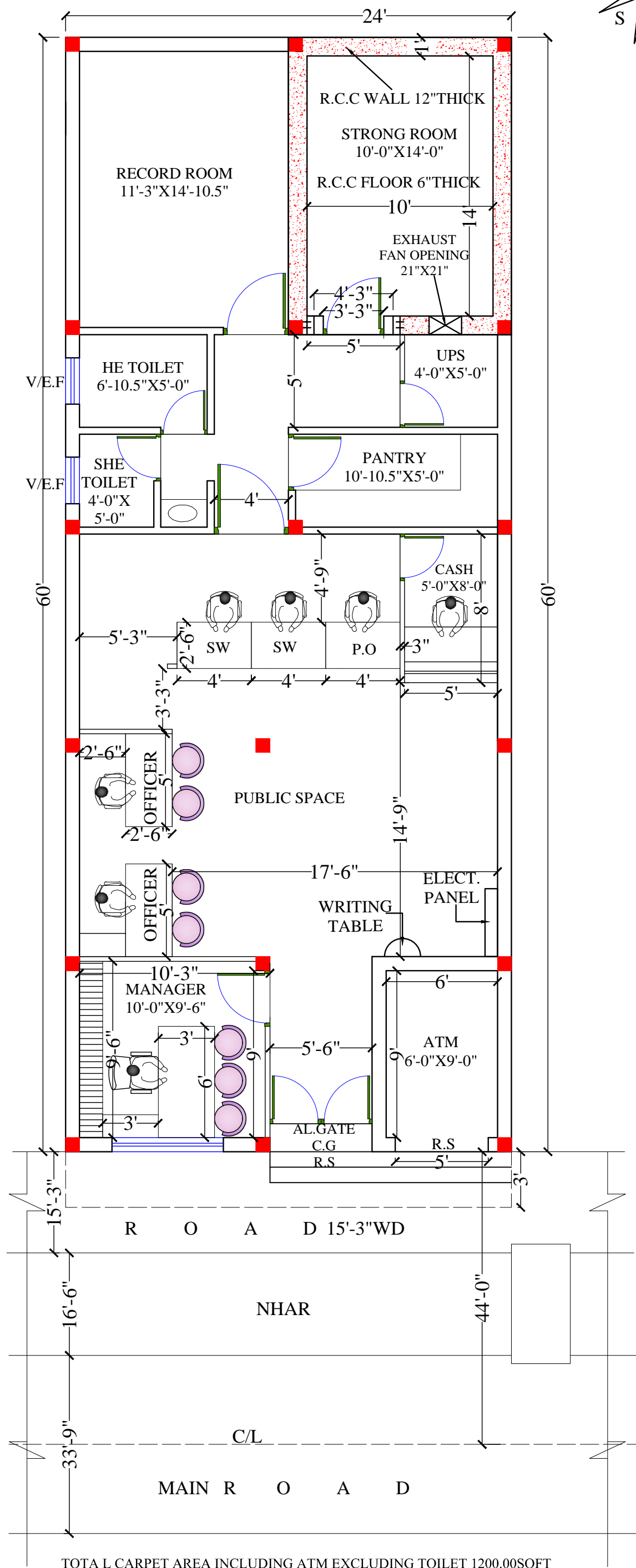
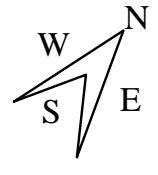





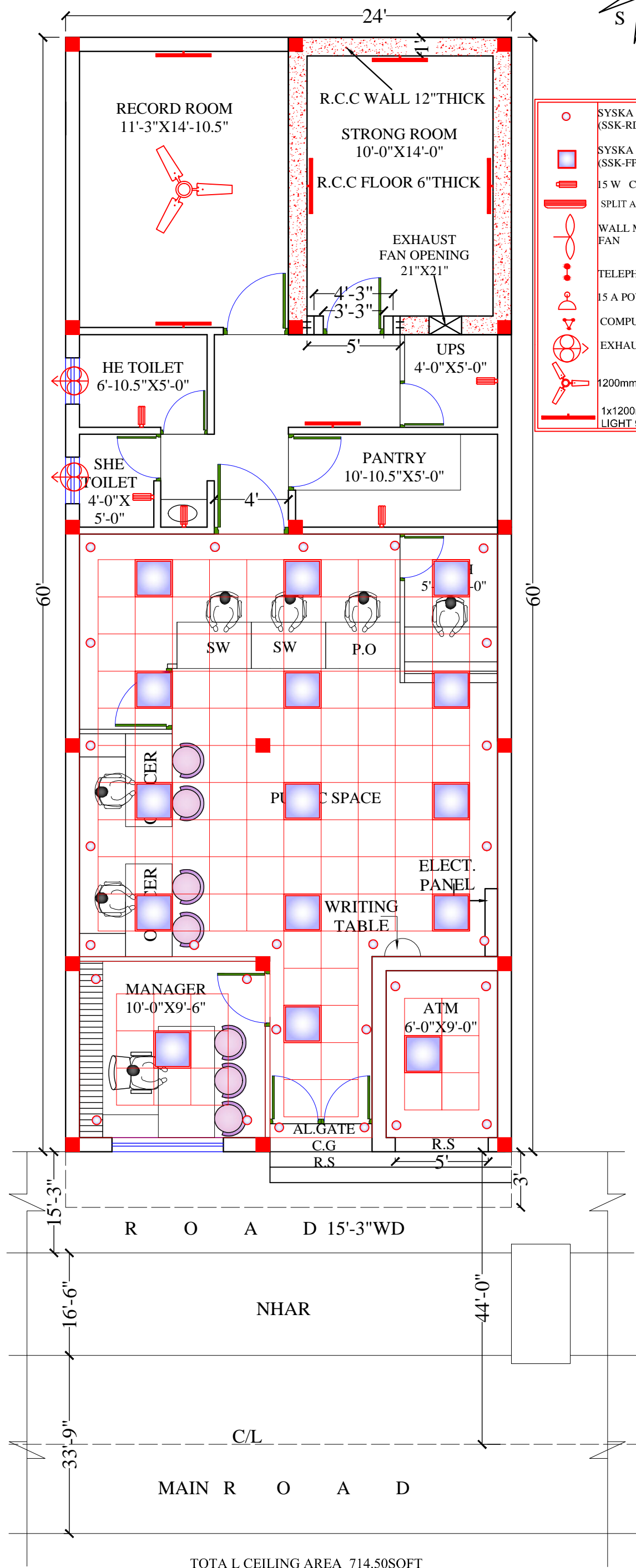
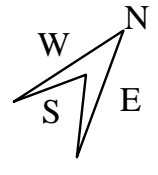

पी.एस.बी



TOTAL CARPET AREA INCLUDING ATM EXCLUDING TOILET 1200.00SQFT

PROJECT NAME: PROP. PLAN FOR P&S BANK SITE AT:- DHAURA TANDA	DRAWING TITLE: GROUND FLOOR PLAN OPTION-3	MAK 97/D/	SCALE	DATE	ARCHITECT: YOGENDRA ARCHITECTS ARCHITECTS, ENGINEERS, & INT. DESIGNERS KAMAL TALKIES BLDG., BAREILLY . PH: 1058112573953
		PRAMOD	N.T.S	07-03-2024	
		DEALT BY	CKD. BY	DEWG. NO.	









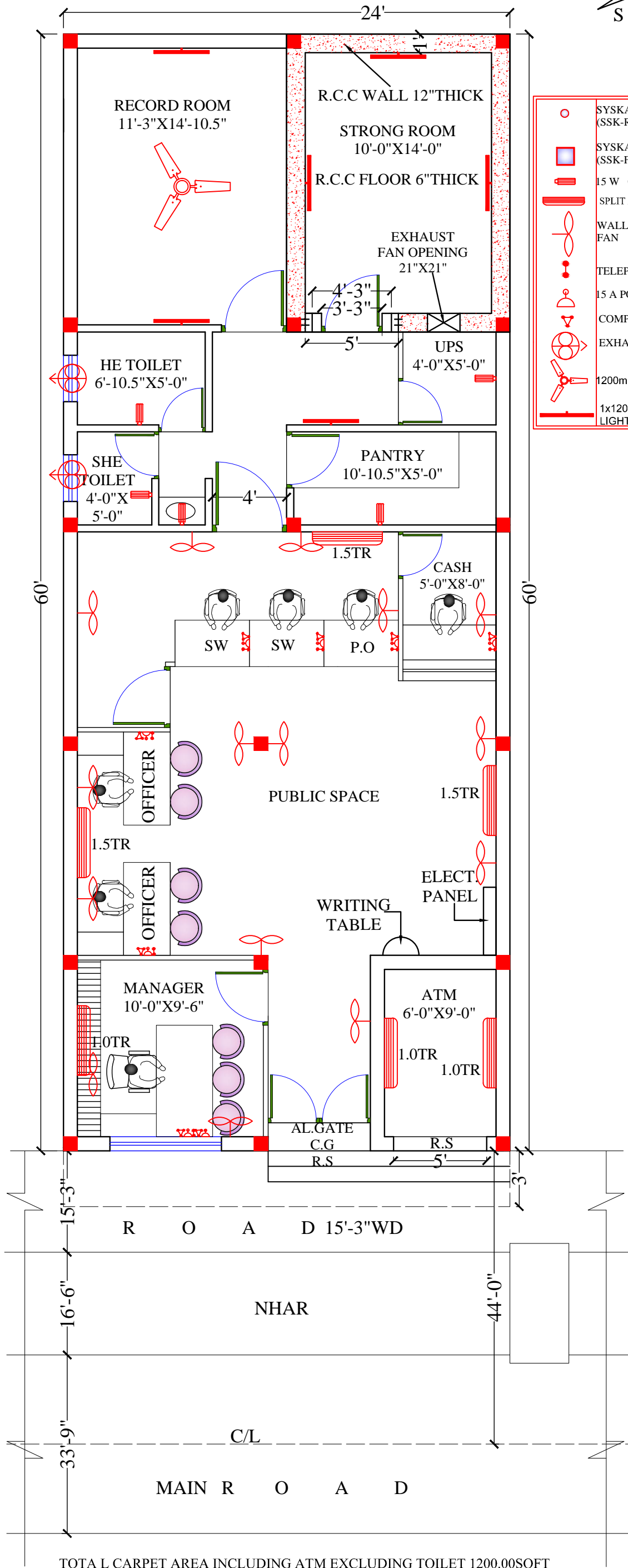
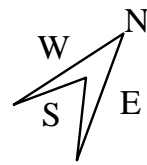



-  SYSKA LED SPOT LIGHT (SSK-RDL-5-12 W)
-  SYSKA 2X2 LED LIGHT (SSK-FP-6060-36)
-  15 W C.F.L.
-  SPLIT A.C.
-  WALL MOUNTED FAN
-  TELEPHONE PT.
-  15 A POWER POINT
-  COMPUTER POINT
-  EXHAUST FAN
-  1200mm CILING FAN
-  1x1200mm LED.TUBE LIGHT 9192 158 50488

TOTAL CEILING AREA 714.50SQFT

PROJECT NAME: PROP. PLAN FOR P&S BANK SITE AT:- DHAURA TANDA	DRAWING TITLE: GROUND FLOOR PLAN CEILING	MAR 27/24 PRAV P&S BANK DHAURA TANDA DEALT BY PRAMOD	SCALE N.T.S CKD. BY	DATE 07-03-2024 DEWG. NO.	ARCHITECT: YOGENDRA ARCHITECTS ARCHITECTS, ENGINEERS, & INT. DESIGNERS KAMAL TALKIES BLDG., BAREILLY . PH: [0581] 2573953
--	--	--	----------------------------------	--	---



-  SYSKA LED SPOT LIGHT (SSK-RDL-5-12 W)
-  SYSKA 2X2 LED LIGHT (SSK-FP-6060-36)
-  15 W C.F.L.
-  SPLIT A.C.
-  WALL MOUNTED FAN
-  TELEPHONE PT.
-  15 A POWER POINT
-  COMPUTER POINT
-  EXHAUST FAN
-  1200mm CILING FAN
-  1x1200mm LED.TUBE LIGHT 9192 158 50488

TOTA L CARPET AREA INCLUDING ATM EXCLUDING TOILET 1200.00SQFT

PROJECT NAME: PROP. PLAN FOR P&S BANK SITE AT:- DHAURA TANDA	DRAWING TITLE: GROUND FLOOR PLAN ELECTRICAL	MAR 27/24 PRAV P&S BANK DHAURA TANDA DEALT BY PRAMOD	SCALE N.T.S CKD. BY	DATE 07-03-2024 DEWG. NO.	ARCHITECT: YOGENDRA ARCHITECTS ARCHITECTS, ENGINEERS, & INT. DESIGNERS KAMAL TALKIES BLDG., BAREILLY . PH: [0581] 2573953
--	---	--	----------------------------------	--	---